SURFACE MOUNT LED TAPE AND REEL

Lead-Free Parts

PRELIMINARYThis is just a preliminary design
to let you evaluate the concept**AM-LG-9S53UYR-HC-T60****DATA SHEET**DOC. NO : IMQW0905-AM-LG-9S53UYR-HC-T60REV. : ADATE : 17 - Oct. - 2018

Features:

1. White SMD with PLCC 2 package.
2. Top view LED Package & Dimensions : 3.0x2.0x0.8 (unit:mm)
3. Luminous color:yellow(Wd:590nm)
4. Viewing angle:120°
5. Compliant with RoHS and REACH

Application:

1. Automotive parts
2. Backlight
3. Interior and Exterior Illumination
4. General applications

Device Selection Guide:

PART NO	MATERIAL	COLOR	
		Emitted	Lens
AM-LG-9S53UYR-HC-T60	AlGaInP	Yellow	Water Clear

Package Dimensions

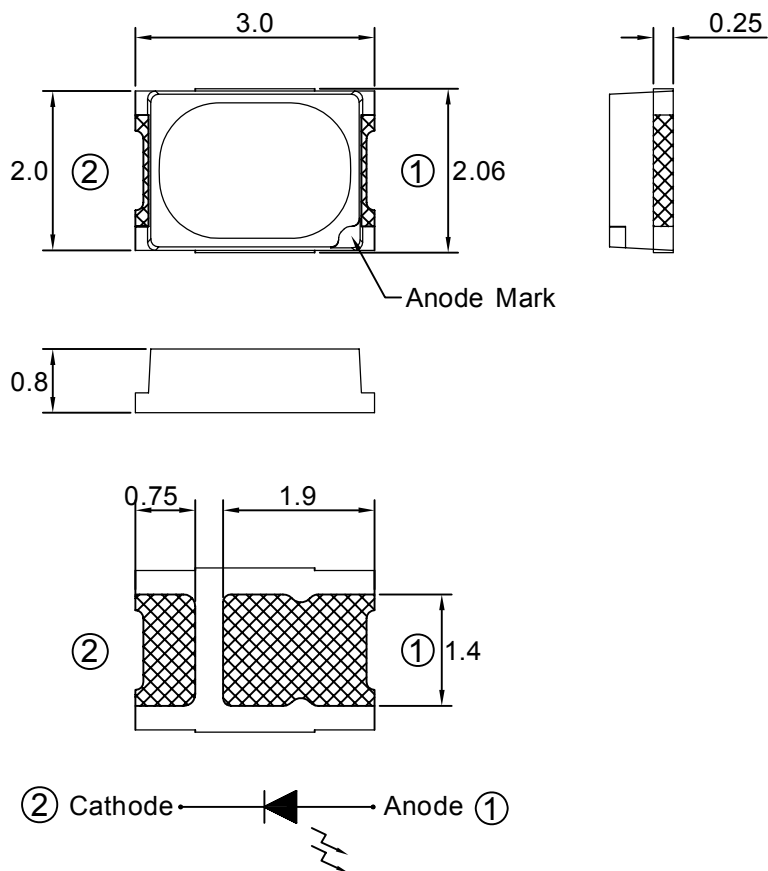

Note : 1.All dimension are in millimeter tolerance is $\pm 0.2\text{mm}$ unless otherwise noted.
2.Specifications are subject to change without notice.

Recommended Soldering Pad Dimensions

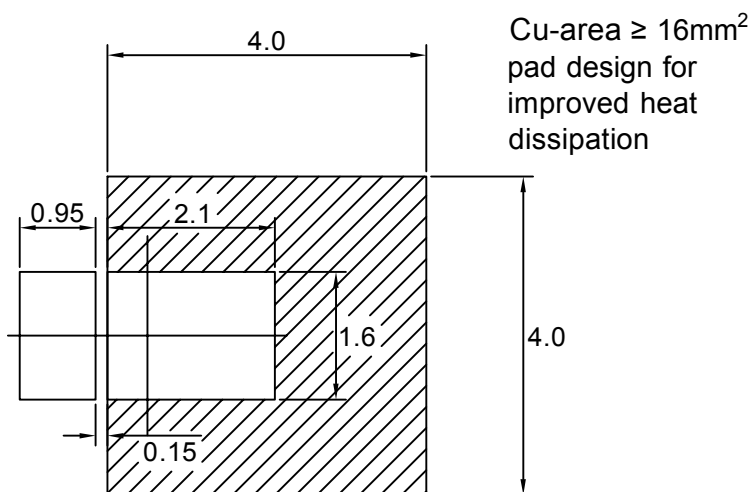

MCPCB Is Recommend

Note : The tolerances unless mentioned is $\pm 0.1\text{mm}$,Unit=mm.

Absolute Maximum Ratings at Ta=25°C

Parameter	Symbol	Ratings	UNIT
		UY(R)	
Forward Current	IF	70	mA
Peak Forward Current Duty 1/10@10KHz	IFP	120	mA
Power Dissipation	PD	196	mW
Reverse Current @12V	Ir	5	μA
Electrostatic Discharge	ESD	2000	V
Operating Temperature	Topr	- 40 ~ + 100	°C
Storage Temperature	Tstg	- 40 ~ + 100	°C
Thermal resistance	Rth j-s	50	°K/W

Typical Electrical & Optical Characteristics (Ta=25°C)

Items	Symbol	Min.	Typ.	Max.	UNIT	CONDITION
Luminous Intensity	Iv	2000	2550	4000	mcd	IF=60mA
Dominant Wavelength	λD	583	590	595	nm	IF=60mA
Spectral Line Half-Width	△λ	----	20	----	nm	IF=60mA
Forward Voltage	V _F	1.9	----	2.8	V	IF=60mA
Viewing Angle	2θ 1/2	----	120	----	deg	IF=60mA

Note : 1.The forward voltage data did not including ±0.1V testing tolerance.

2.The luminous intensity data did not including ±15% testing tolerance.

Luminous Intensity Classification

BIN CODE	Iv(mcd) at 60mA	
	Min.	Max.
X-1	2000	2550
X-2	2550	3200
Y-1	3200	4000

Dominant Wavelength Classification

BIN CODE	λD (nm) at 60mA	
	Min.	Max.
Y1	583	586
Y2	586	589
Y3	589	592
Y4	592	595

Forward Voltage Classification

BIN CODE	Vf(v) at 60mA	
	Min.	Max.
2	1.90	2.05
3	2.05	2.20
4	2.20	2.35
5	2.35	2.50
6	2.50	2.65
7	2.65	2.80

Typical Electro-Optical Characteristics Curve

Fig.1 Forward current vs. Forward Voltage

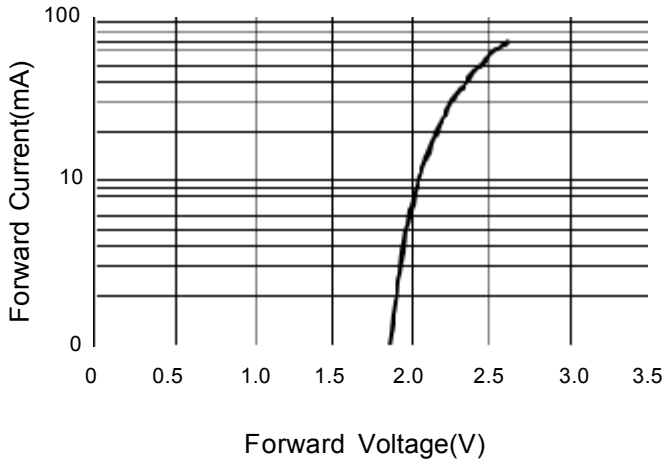

Fig.2 Luminous Intensity vs. Forward Current

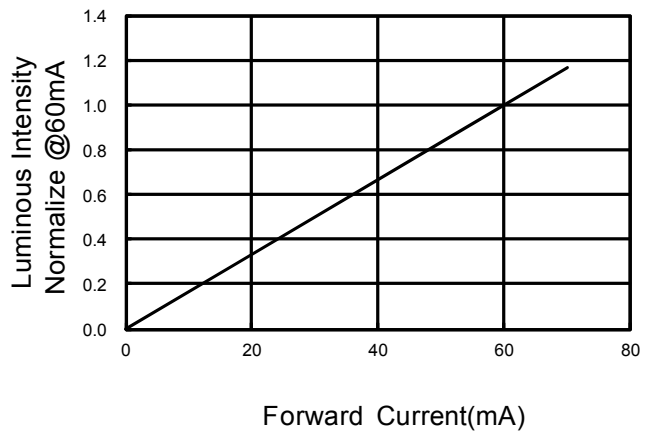

Fig.3 Forward Current vs. Temperature

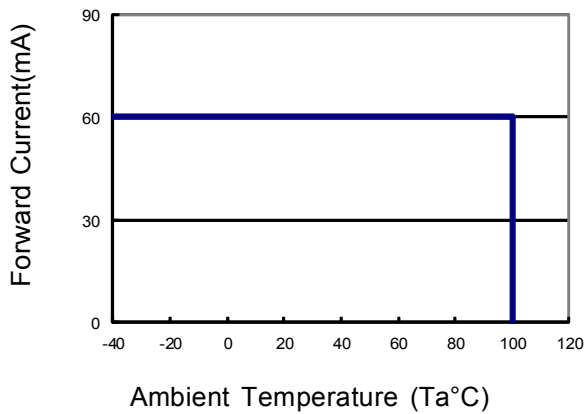

Fig.4 Luminous Intensity vs. Temperature

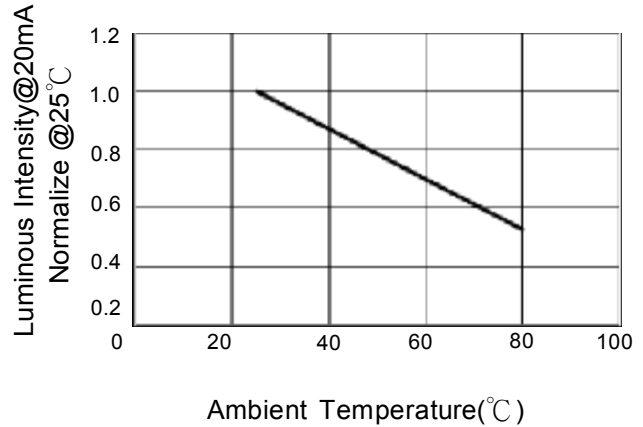

Fig.5 Relative Intensity vs. Wavelength

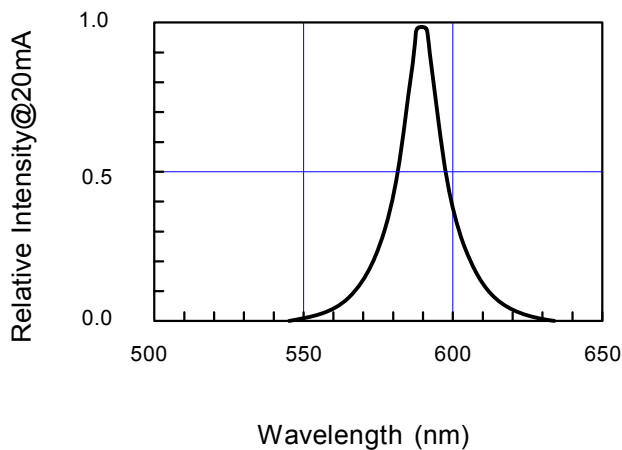
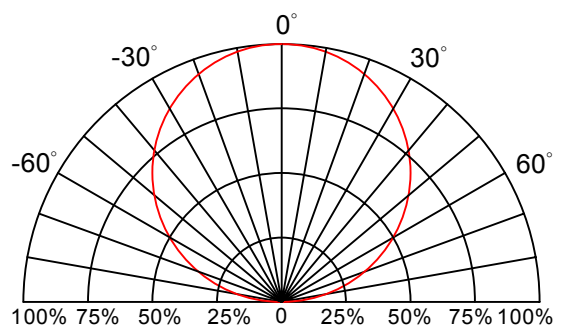
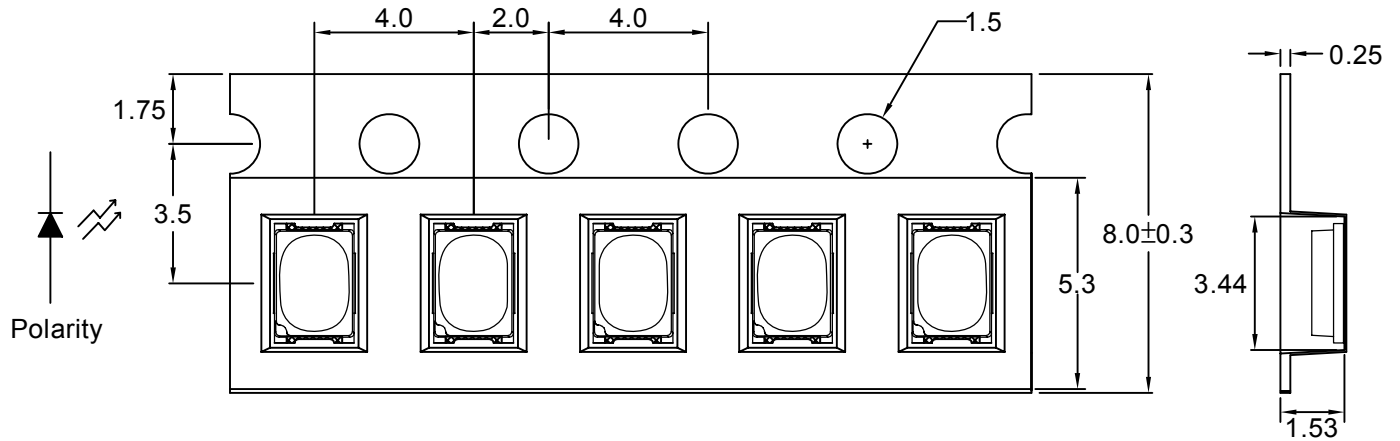

Fig.6 Directive Radiation



Carrier Type Dimensions





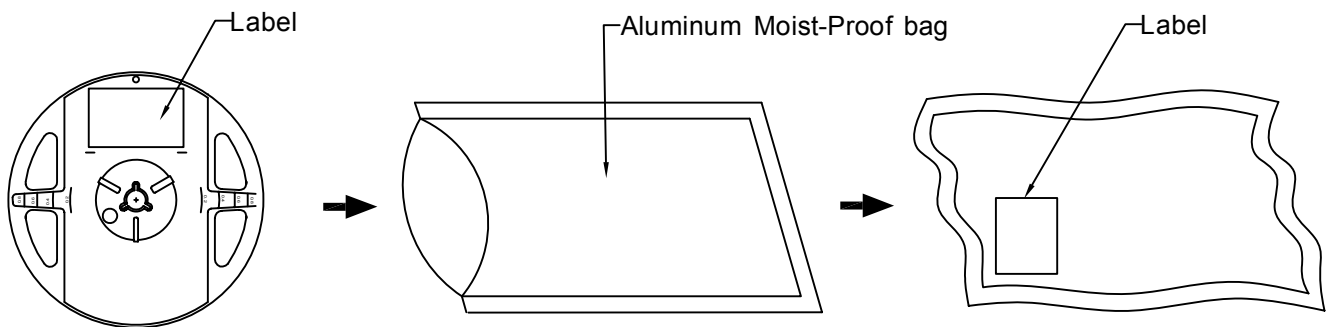

Note : The tolerances unless mentioned is ± 0.1 mm, Unit=mm.

Packing Specifications



Part No.	Description	Quantity/Reel
AM-LG-9S53UYR-HC-T60	8.0mm tape, 7" reel	2000 PCS

Label Explanation

	LIGITEK ELECTRONICS CO., LTD.	
PART :	AM-LG-9S53UYR-HC-T60	
LOT :	GS11620168	
QTY(PCS):	2000	
BIN/HUE :	X-1/Y1	 VF:2.05-2.2

BIN : Luminous Intensity

HUE : Dominant Wavelength

VF : Forward Voltage

Reel Dimensions

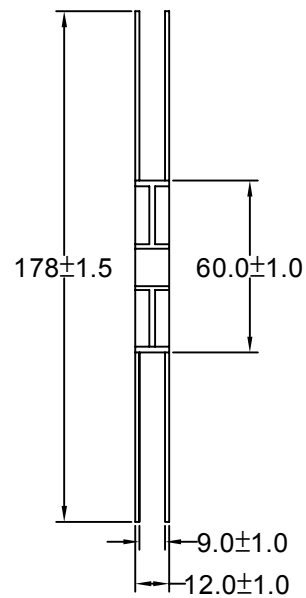
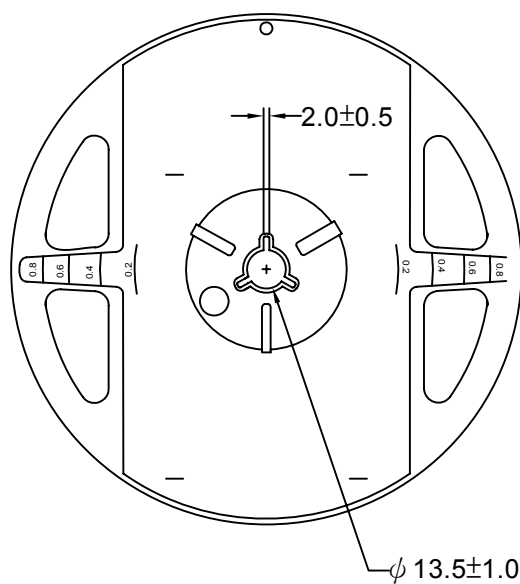

Box Explanation

1. 5 BAG / INNER BOX

2. INNER BOX SIZE : L X W X H 23cm X 8.5cm x 26cm

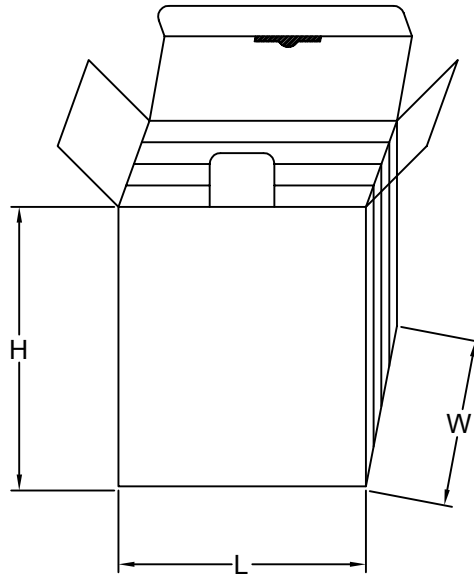

3. 10 INNER BOXES / CARTON

4. CARTON SIZE : L X W X H 58cm X 34cm x 35cm

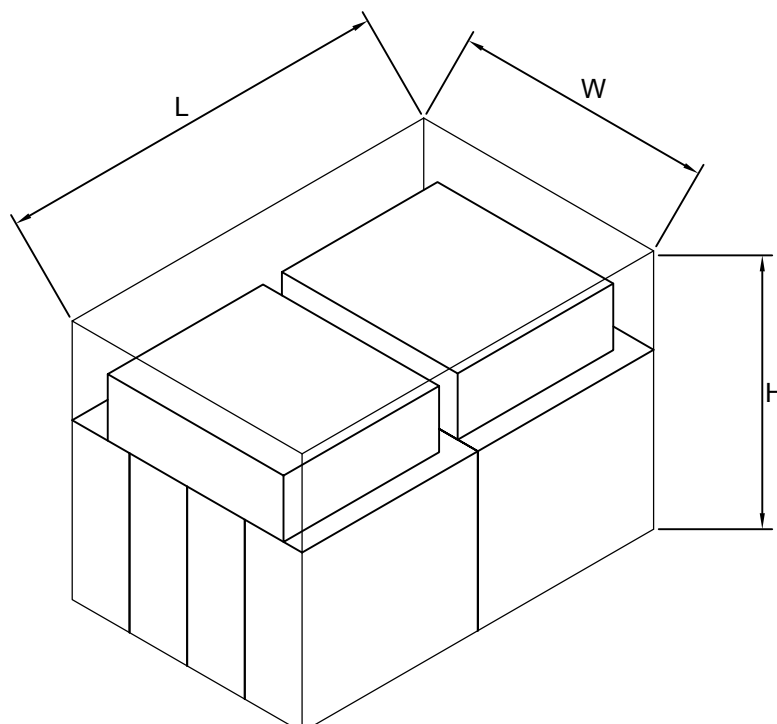

Recommended Soldering Conditions**1. Hand Solder**

Basic spec is $\leq 320^{\circ}\text{C}$ 3 sec one time only.

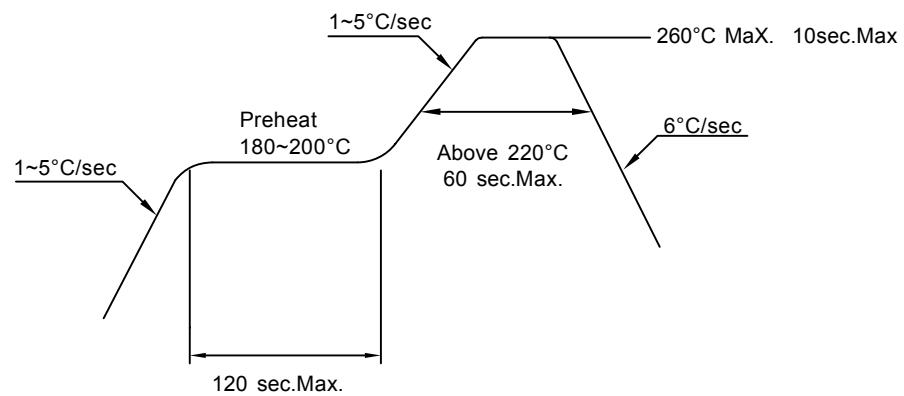
2. PB-Free Reflow Solder**Note:**

- 1.Reflow soldering should not be done more than two times.
- 2.When soldering,do not put stress on the LEDs during heating.
- 3.After soldering,do not warp the circuit board.

Precautions For Use:**Storage time:**

1. Calculated shelf life before opening is 12 months at $< 30^{\circ}\text{C}$ and $< 90\%$ relative humidity (RH)
 2. After bag is opened, devices which will be subjected to reflow soldering or other high temperature processes must be
 - a) Assembled within 168 hours in an environment of $\leq 30^{\circ}\text{C} / 60\%$ RH, or
 - b) Stored at ambient of 10% RH or less
 3. Devices are required baking before assembly if:
 - a) Humidity Indicator Card reads $>10\%$ (for level 2a -5a) or $>60\%$ (for level 2) at ambient temperature $23\pm 5^{\circ}\text{C}$
 - b) 2.a) or 2.b) doesn't meet
 4. If baking is required, devices should be baked for >72 hours at $60\pm 5^{\circ}\text{C} / 5\%$ RH. Performing baking only once, and using the baked devices within 72 hours.
- MSL LEVEL 3

Drive Method:

LED is a current operated device, and therefore, requires some kind of current limiting incorporated into the driver circuit. This current limiting typically takes the form of a current limiting resistor placed in series with the LED.

Consider worst case voltage variations than could occur across the current limiting resistor. The forward current should not be allowed to change by more than 40% of its desired value.

Circuit model A

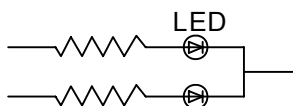

Circuit model B

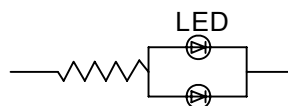

(A) Recommended circuit.

(B) The difference of brightness between LED could be found due to the VF-IF characteristics of LED.

Cleaning:

Use alcohol-based cleaning solvents such as isopropyl alcohol to clean the LED.

ESD(Electrostatic Discharge):

Static Electricity or power surge will damage the LED. Use of a conductive wrist band or anti-electrostatic glove is recommended when handling these LED. All devices, equipment and machinery must be properly grounded.