



---

SURFACE MOUNT LED TAPE AND REEL



Lead-Free Parts

AM-LG-3433UYR-T140

# DATA SHEET

DOC. NO : QW0905-AM-LG-3433UYR-T140

REV. : A

DATE : 25 - Mar. - 2019

## Features:

1. White SMD with PLCC6 package.
2. Top view LED Package & Dimensions : 3.4x3.3x1.9 (unit:mm)
3. Luminous color:yellow(Wd:590nm)
4. Viewing angle:120°
5. Compliant with RoHS and REACH
6. Qualification according to AEC-Q101

## Application:

1. Automotive parts
2. Backlight
3. Interior and Exterior Illumination
4. General applications

## Device Selection Guide:

PART NO	MATERIAL	COLOR	
		Emitted	Lens
AM-LG-3433UYR-T140	AlGaInP	Yellow	Water Clear

## Package Dimensions

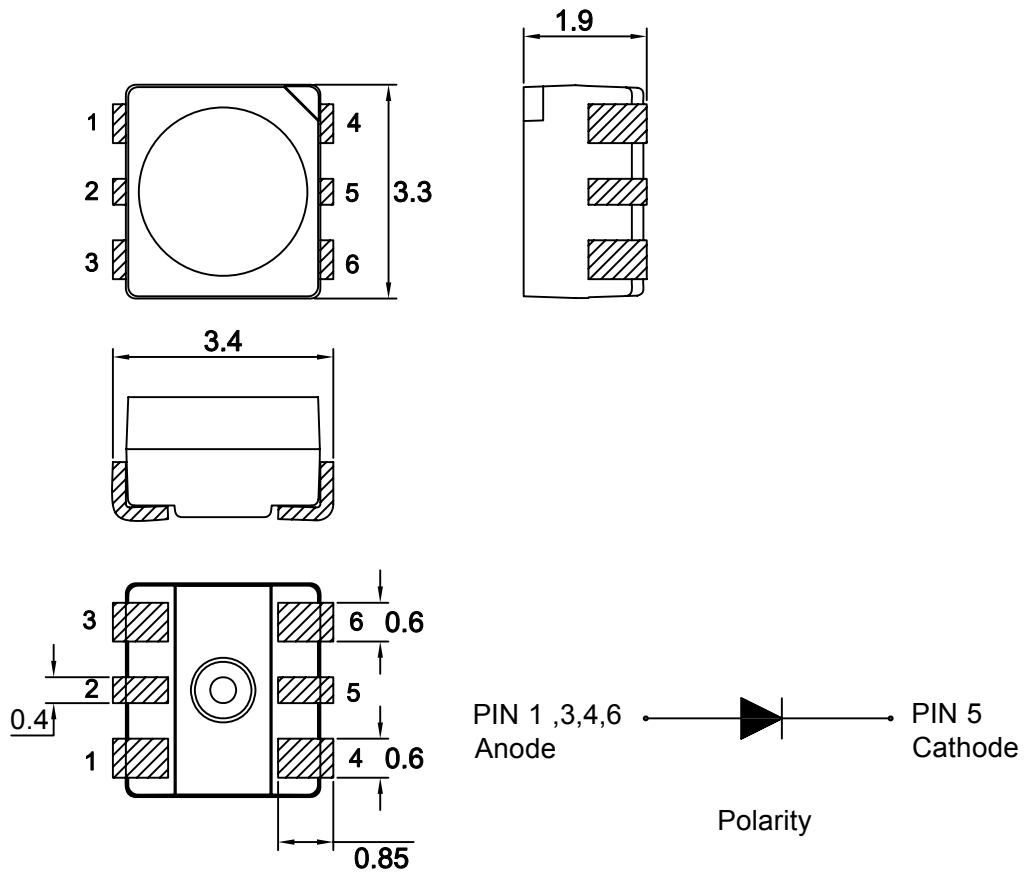

Note : 1.All dimension are in millimeter tolerance is  $\pm 0.2\text{mm}$  unless otherwise noted.  
2.Specifications are subject to change without notice.

## Recommended Soldering Pad Dimensions

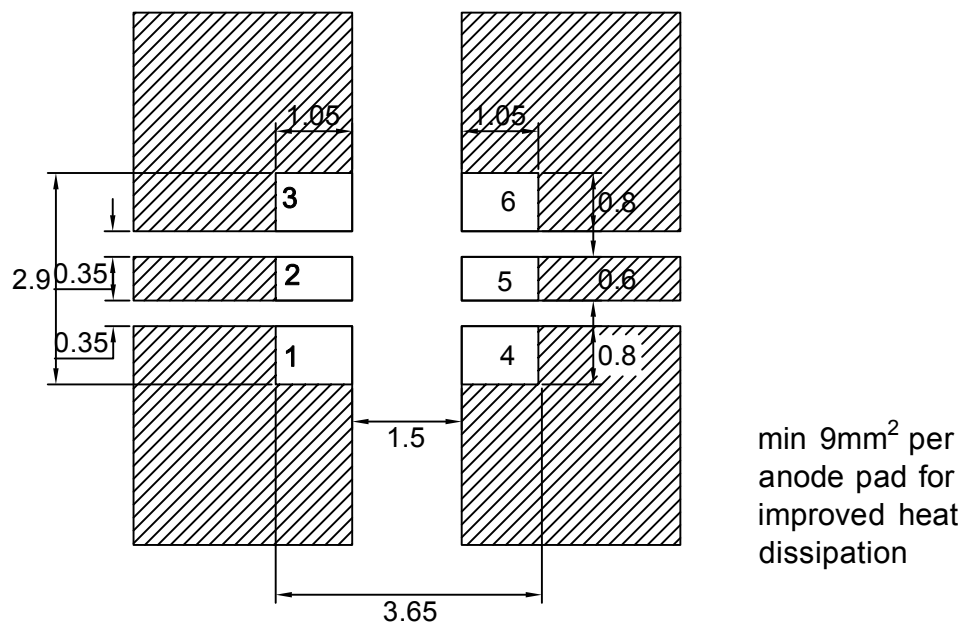

Note : The tolerances unless mentioned is  $\pm 0.1\text{mm}$ . Unit=mm.

### Absolute Maximum Ratings at Ta=25°C

Parameter	Symbol	Ratings	UNIT
Forward Current	IF	200	mA
Peak Forward Current Duty 1/10@10KHz	IFP	400	mA
Power Dissipation	PD	600	mW
Reverse Current @12V	Ir	5	μA
Electrostatic Discharge	ESD	2000	V
Operating Temperature	T <sub>opr</sub>	- 40 ~ + 100	°C
Storage Temperature	T <sub>stg</sub>	- 40 ~ + 100	°C
LED junction Temperature	T <sub>j</sub>	125	°C
Thermal resistance*	R <sub>th j-s</sub>	60	°C/W

### Typical Electrical & Optical Characteristics (Ta=25°C)

Items	Symbol	Min.	Typ.	Max.	UNIT	CONDITION
Luminous Intensity	I <sub>v</sub>	----	7.1	----	cd	IF=140mA
Dominant Wavelength	λ <sub>D</sub>	----	590	----	nm	IF=140mA
Spectral Line Half-Width	Δλ	----	15	----	nm	IF=140mA
Forward Voltage	V <sub>F</sub>	1.6	----	3.0	V	IF=140mA
Viewing Angle	2θ 1/2	----	120	----	deg	IF=140mA

- Note : 1.The forward voltage data did not including ±0.1V testing tolerance.  
 2.The luminous intensity data did not including ±15% testing tolerance.  
 3.The dominant wavelength data did not including ±1nm testing tolerance

### Luminous Intensity Classification

BIN CODE	Iv(cd) at140mA	
	Min.	Max.
A	3.55	4.50
B	4.50	5.60
C	5.60	7.10
D	7.10	9.00
E	9.00	11.20

### Dominant Wavelength Classification

BIN CODE	$\lambda_D$ (nm) at140mA	
	Min.	Max.
Y1	583	586
Y2	586	589
Y3	589	592
Y4	592	595

## Typical Electro-Optical Characteristics Curve

### UYR CHIP

Fig.1 Forward current vs. Forward Voltage

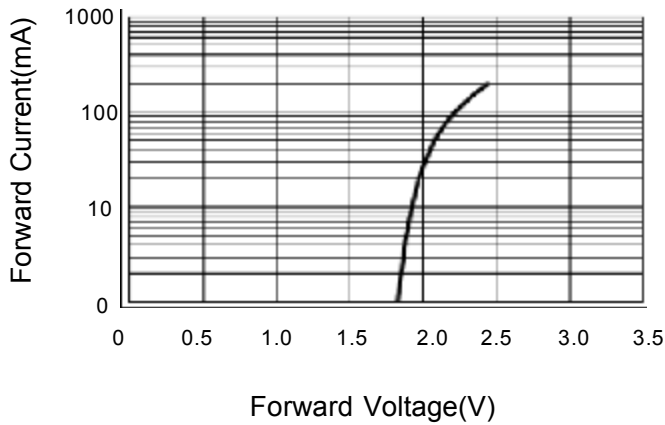

Fig.2 Luminous Intensity vs. Forward Current

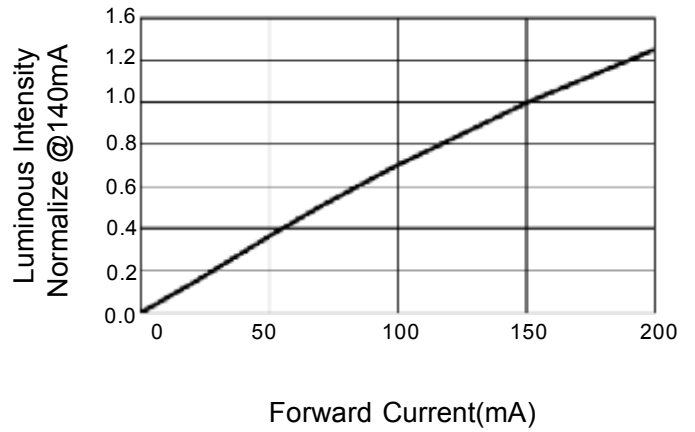

Fig.3 Forward Voltage vs. Temperature

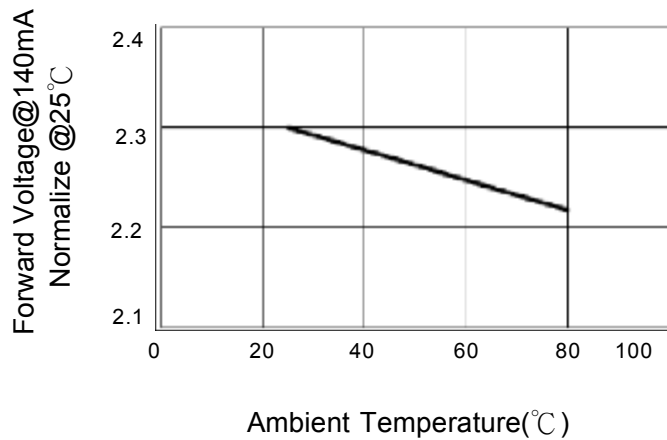

Fig.4 Luminous Intensity vs. Temperature

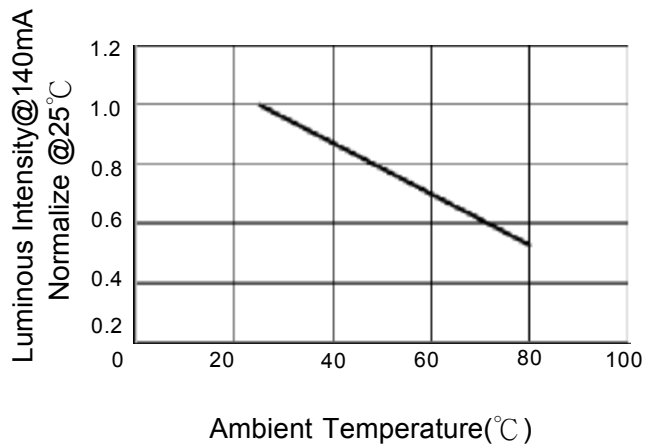

Fig.5 Relative Intensity vs. Wavelength

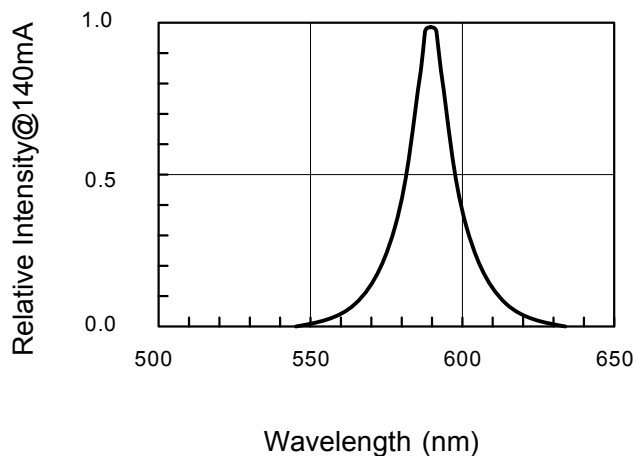
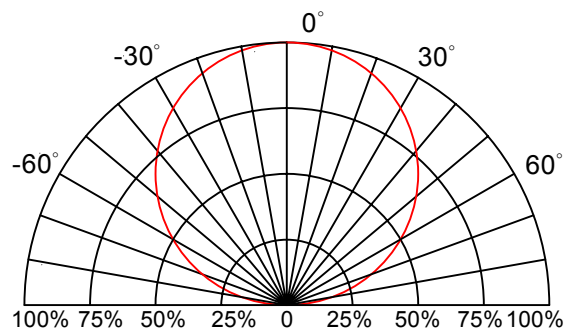
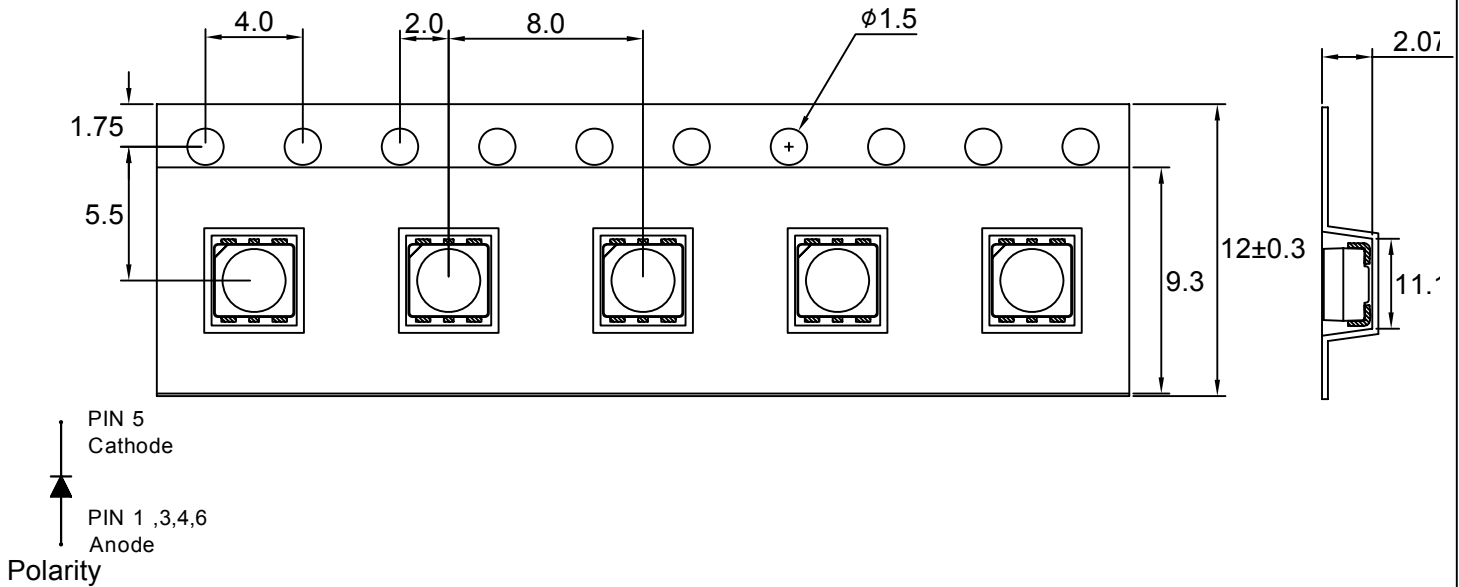

Fig.6 Directive Radiation



## Carrier Type Dimensions





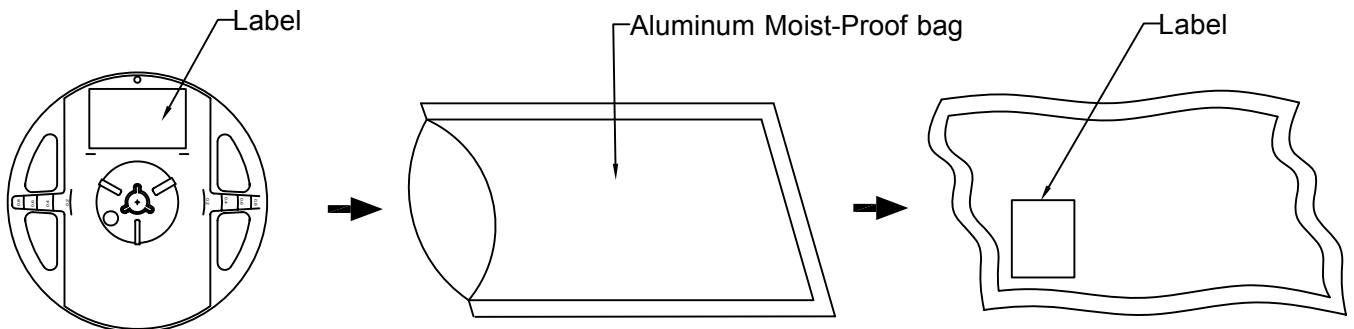

Note : The tolerances unless mentioned is  $\pm 0.1$ mm,Unit=mm.

## Packing Specifications



Part No.	Description	Quantity/Reel
AM-LG-3433UYR-T140	12.0mm tape,7"reel	----- PCS

## Label Explanation

	LIGITEK ELECTRONICS CO., LTD.	
PART :	AM-LG-3433UYR-T140	
LOT :	GS11680168	
QTY(PCS):	xxxx	
BIN/HUE :	A/Y-1	 VF:1.6-3.0

BIN : Luminous Intensity

HUE : Dominant Wavelength

VF : Forward Voltage

## Reel Dimensions

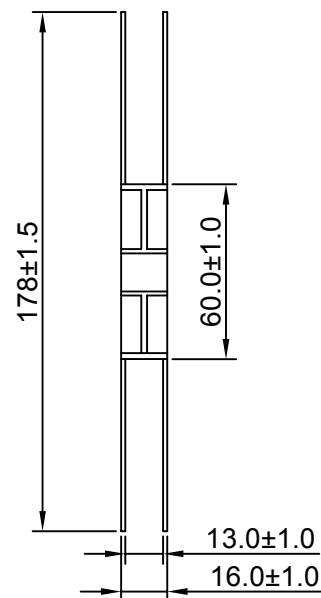
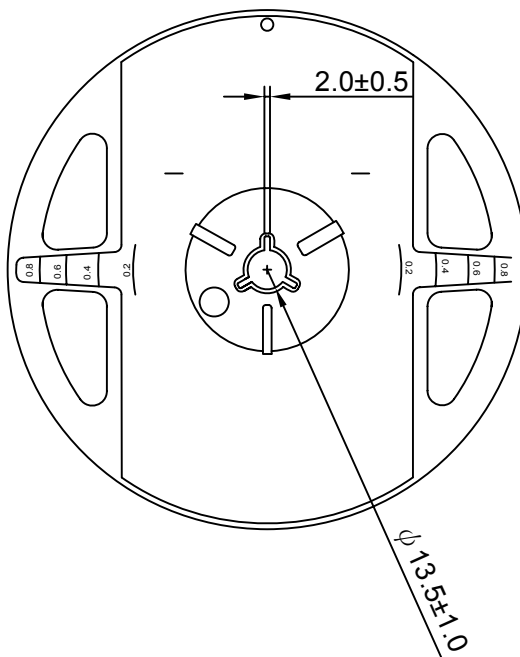



## Box Explanation

1. 5 BAG / INNER BOX
2. INNER BOX SIZE : L X W X H 23cm X 8.5cm x 26cm

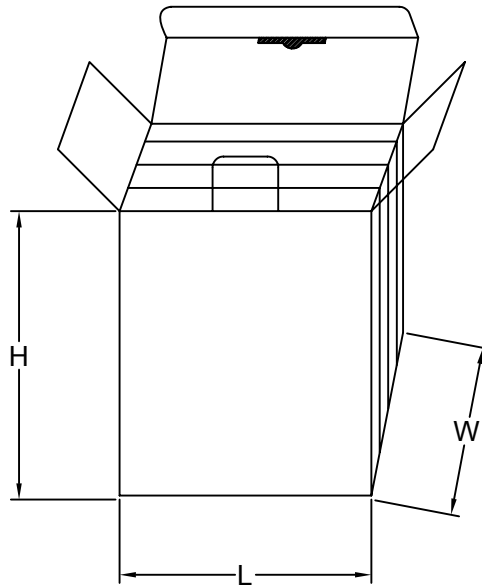

3. 10 INNER BOXES / CARTON
4. CARTON SIZE : L X W X H 58cm X 34cm x 35cm

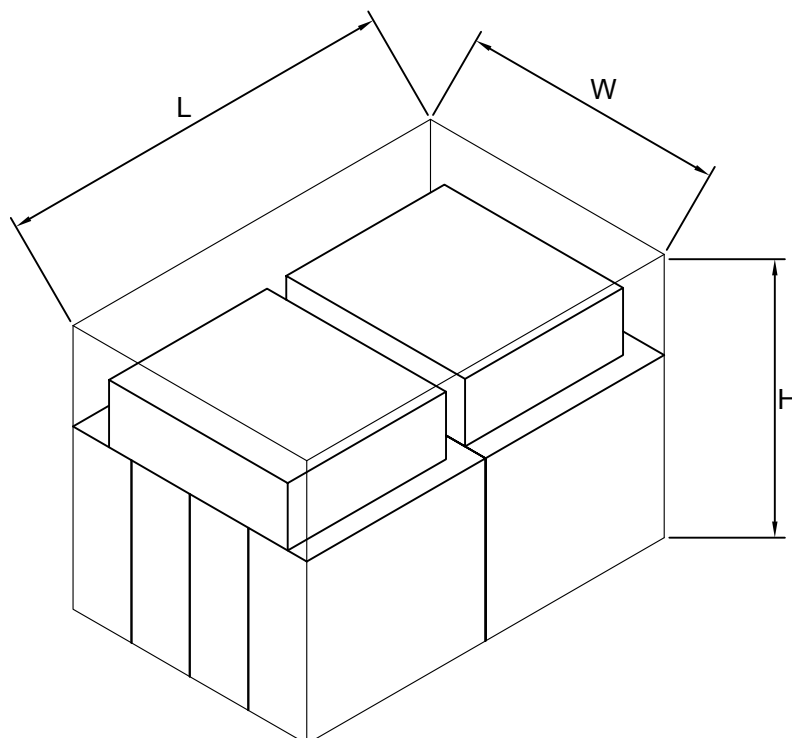

**Recommended Soldering Conditions****1. Hand Solder**

Basic spec is  $\leq 320^{\circ}\text{C}$  3 sec one time only.

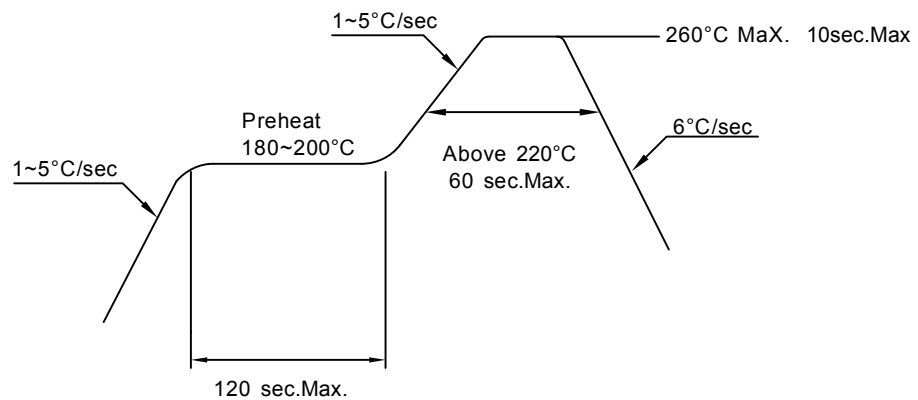
**2. PB-Free Reflow Solder****Note:**

- 1.Reflow soldering should not be done more than two times.
- 2.When soldering,do not put stress on the LEDs during heating.
- 3.After soldering,do not warp the circuit board.

**Precautions For Use:****Storage time:**

1. Calculated shelf life before opening is 12 months at  $< 30^{\circ}\text{C}$  and  $< 90\%$  relative humidity (RH)
2. After bag is opened, devices which will be subjected to reflow soldering or other high temperature processes must be
  - a) Assembled within 168 hours in an environment of  $\leq 30^{\circ}\text{C} / 60\%$  RH, or
  - b) Stored at ambient of 10% RH or less
3. Devices are required baking before assembly if:
  - a) Humidity Indicator Card reads  $>10\%$  (for level 2a -5a) or  $>60\%$  (for level 2) at ambient temperature  $23\pm 5^{\circ}\text{C}$
  - b) 2.a) or 2.b) doesn't meet
4. If baking is required, devices should be baked for  $>72$  hours at  $60\pm 5^{\circ}\text{C} / 5\%$  RH. Performing baking only once, and using the baked devices within 72 hours.  
MSL LEVEL 3

**Drive Method:**

LED is a current operated device, and therefore, requires some kind of current limiting incorporated into the driver circuit. This current limiting typically takes the form of a current limiting resistor placed in series with the LED.

Consider worst case voltage variations than could occur across the current limiting resistor. The forward current should not be allowed to change by more than 40% of its desired value.

Circuit model A

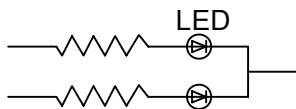

Circuit model B

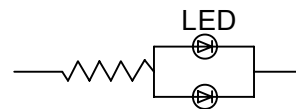

(A) Recommended circuit.

(B) The difference of brightness between LED could be found due to the VF-IF characteristics of LED.

**Cleaning:**

Use alcohol-based cleaning solvents such as isopropyl alcohol to clean the LED.

**ESD(Electrostatic Discharge):**

Static Electricity or power surge will damage the LED. Use of a conductive wrist band or anti-electrostatic glove is recommended when handling these LED. All devices, equipment and machinery must be properly grounded.

Reliability Test:

Classification	Test Item	Test Condition	Sample Size
Endurance Test	Operating Life Test	1.Ta=25°C 2.If=140mA 3.t=1000 hrs (-24hrs,+72hrs)	22
	High Temperature Storage Test	1.Ta=100°C±5°C 2.t=1000 hrs (-24hrs,+72hrs)	22
	Low Temperature Storage Test	1.Ta=-40°C±5°C 2.t=1000 hrs (-24hrs,+72hrs)	22
	High Temperature High Humidity Storage Test	1.Ta=85°C 2.RH=85% 3.t=1000hrs(-24hrs,+72hrs)	22
Environmental Test	Thermal Shock Test	1.Ta=100°C±5°C ~ -40°C±5°C 20min/ 10sec / 20min 2.total 100 cycles	22
	Temperature Cycling	1.100°C±5°C ~ -40°C±5°C 30mins / 5mins / 30mins 2.100 Cyeles	22
	IR Reflow	1.T=260°C Max. 10sec.Max. 2. 6 Min	22