



LIGITEK ELECTRONICS CO.,LTD.  
Property of Ligitek Only

SURFACE MOUNT LED TAPE AND REEL



Lead-Free Parts

LG-2835W-1-T150-D702

## DATA SHEET

DOC. NO : QW0905-LG-2835W-1-T150-D702

REV. : A

DATE : 30 - Mar. - 2015



### Features:

1. Top view white LED.
2. white SMT package.
3. Leadframe package with individual 2 pin.
4. Wide viewing angle.
5. Soldering methods: IR reflow soldering.
6. Feature of the device: more light due to higher optical efficiency; extremely wide viewing angle; ideal for backlighting and coupling in light guide.

### Descriptions:

The LG-2835 SMD has wide viewing angle, low power consumption and white LEDs are devices which are materialized by combining blue LEDs and special phosphors. This feature makes the LED ideal for light guide application.

### Applications:

1. LCD back light.
2. Mobile phones.
3. Indicators.
4. Switch lights.

### Device Selection Guide:

PART NO	MATERIAL	COLOR	
		Emitted	Lens
LG-2835W-1-T150-D702	InGaN	White	Yellow Diffused

**Package Dimensions**

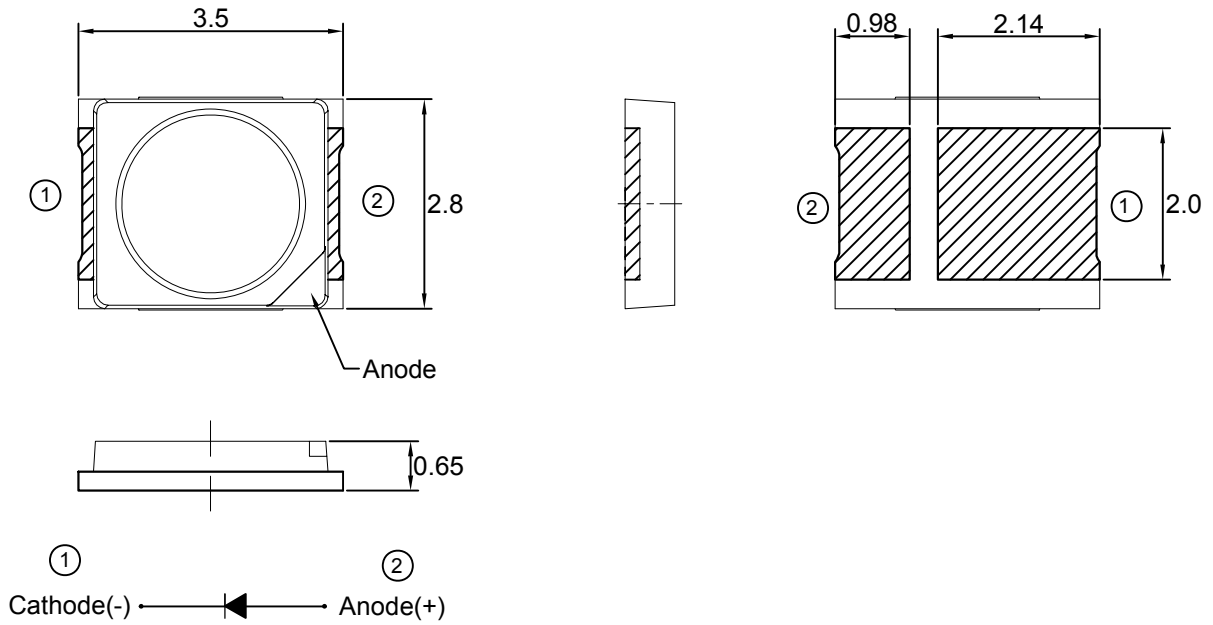

Note : 1.All dimension are in millimeter tolerance is  $\pm 0.2\text{mm}$  unless otherwise noted.  
 2.Specifications are subject to change without notice.

**Recommended Soldering Pad Dimensions**

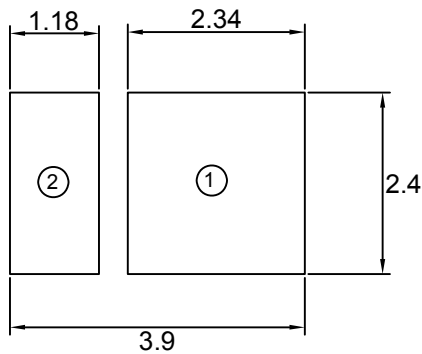

Note : The tolerances unless mentioned is  $\pm 0.1\text{mm}$ , Unit=mm.

### Absolute Maximum Ratings at Ta=25 °C

Parameter	Symbol	Ratings	UNIT
Forward Current	IF	150	mA
Peak Forward Current Duty 1/10@10KHz	IFP	300	mA
Power Dissipation	PD	570	mW
Reverse Current @5V	Ir	50	μA
Electrostatic Discharge	ESD	500	V
Operating Temperature	Topr	- 20 ~ + 80	°C
Storage Temperature	Tstg	- 30 ~ + 100	°C
LED junction Temperature	Tj	125	°C

### Typical Electrical & Optical Characteristics (Ta=25 °C)

Items	Symbol	Min.	Typ.	Max.	UNIT	CONDITION
Luminous Intensity	Iv	50	55	----	lm	IF=150mA
Chromaticity Coordinates	X	0.4147	----	0.4562	----	IF=150mA
	Y	0.3814	----	0.4260	----	IF=150mA
Forward Voltage	V <sub>F</sub>	2.8	----	3.8	V	IF=150mA
Viewing Angle	2θ 1/2	----	120	----	deg	IF=150mA
Color Rendering Index	CRI	70	----	---	----	IF=150mA

- Note :
- 1.The forward voltage data did not including ±0.1V testing tolerance.
  - 2.The luminous intensity data did not including ±15% testing tolerance.
  - 3.The color coordinates measurement allowance is ±0.01 testing tolerance
  - 4.4.The CRI measurement allowance is ±2 testing tolerance.

### Luminous Intensity Classification

BIN CODE	Iv(lm) at150mA	
	Min.	Max.
F50V	50	55
F55V	55	60
F60V	60	65
F65V	65	70
F70V	70	75

### Forward Voltage Classification

BIN CODE	Vf(v) at150mA	
	Min.	Max.
1	2.8	3
2	3	3.2
3	3.2	3.4
4	3.4	3.6
5	3.6	3.8

**Chromaticity Coordinates Specifications For Bin Grading**

Color Coordiante at150mA								
BIN CODE	1		2		3		4	
	X	Y	X	Y	X	Y	X	Y
30K-1	0.4562	0.426	0.4431	0.4213	0.4345	0.4033	0.4468	0.4077
30K-2	0.4468	0.4077	0.4345	0.4033	0.426	0.3854	0.4373	0.3893
30K-3	0.4431	0.4213	0.4299	0.4165	0.4223	0.399	0.4345	0.4033
30K-4	0.4345	0.4033	0.4223	0.399	0.4147	0.3814	0.426	0.3854

**CIE Chromaticity Diagram**

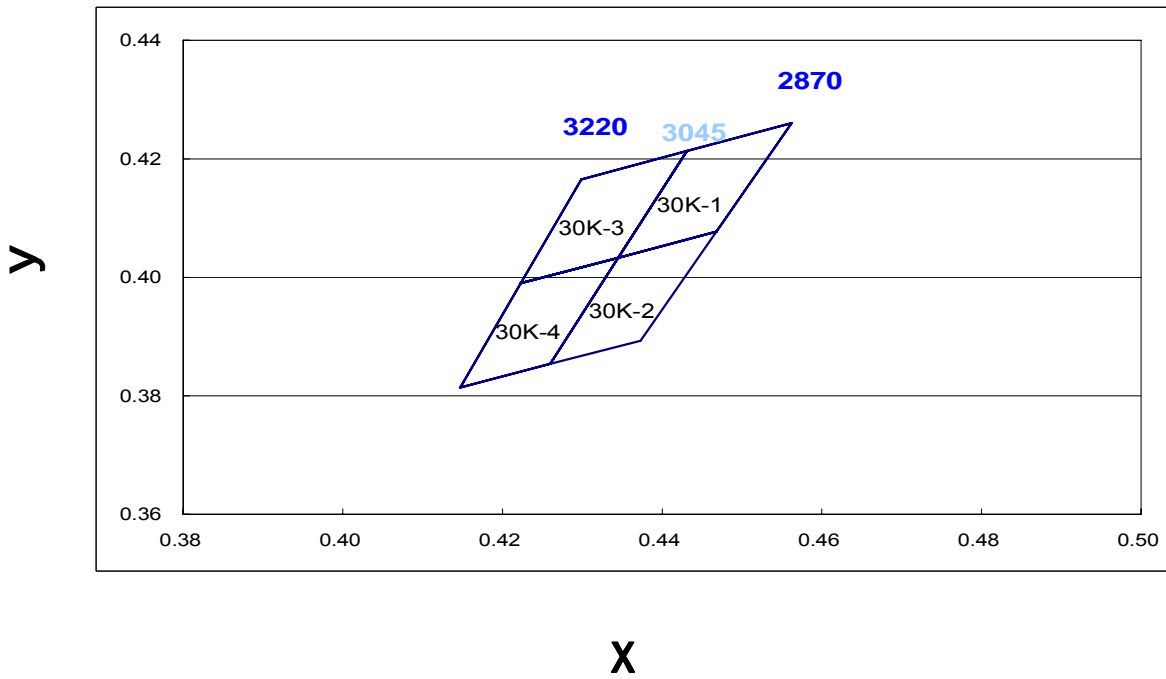

## Typical Electro-Optical Characteristics Curve

Fig.1 Forward current vs. Forward Voltage

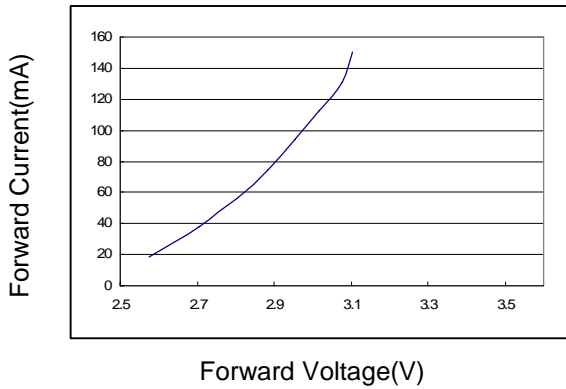

Fig.3 Max. Driving Forward Current VS. Soldering Temperature

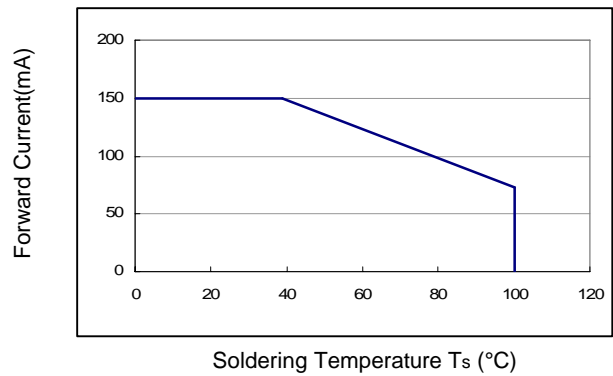

Fig.2 Forward current vs. Luminous Intensity

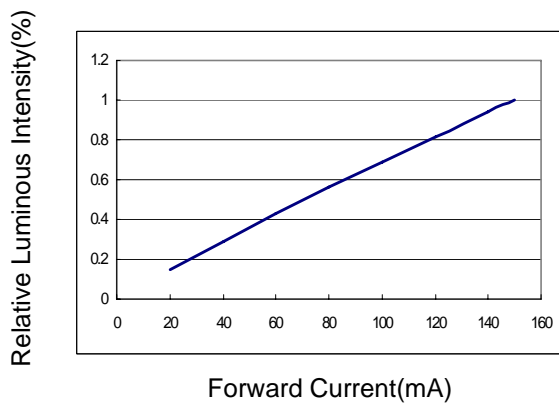

Fig.4 Forward Voltage vs. Temperature

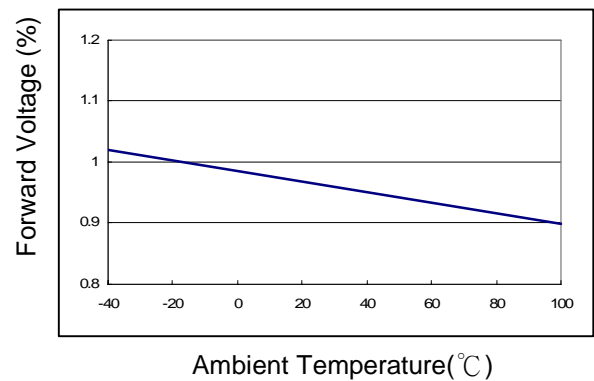

Fig.5 Luminous Spectrum ( $T_a=25^\circ\text{C}$ )

SPECTRAL RADIANCE

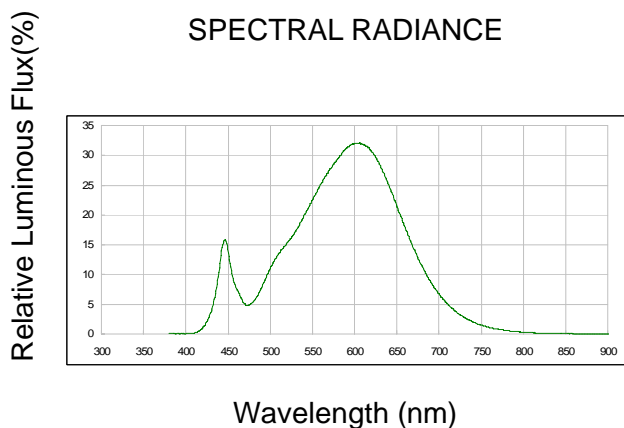
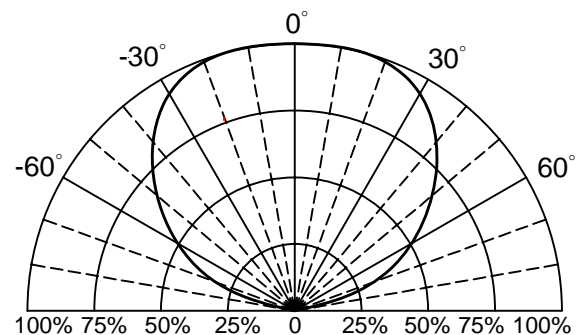
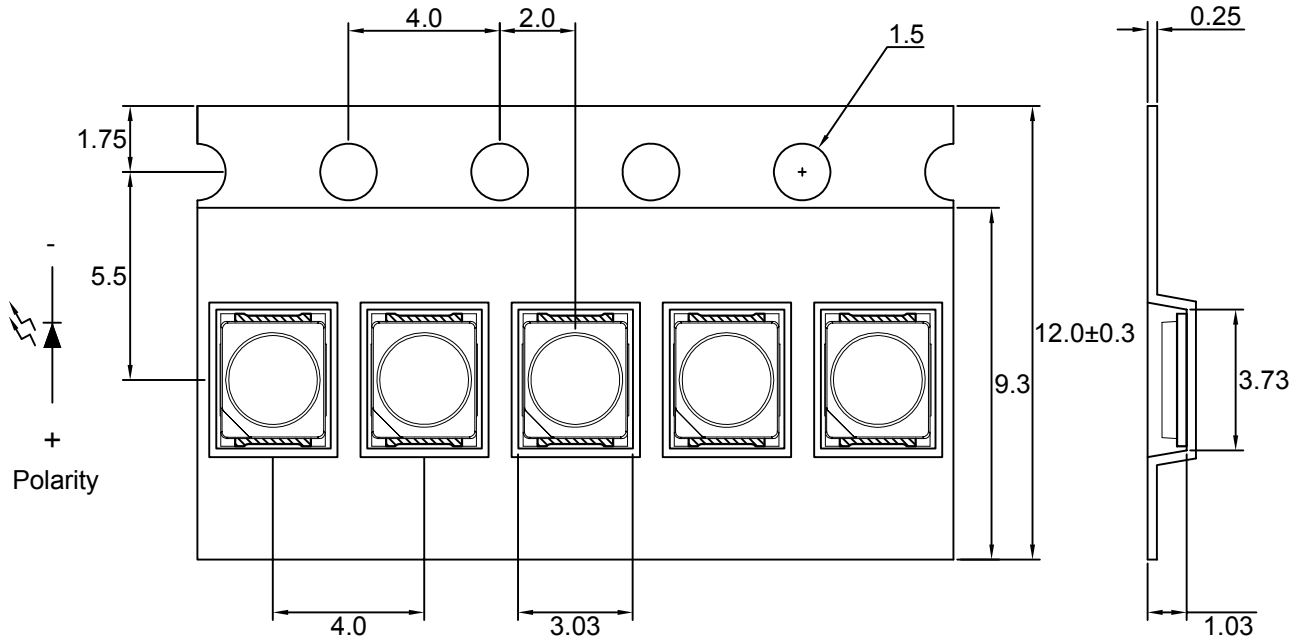

Fig.6 Directivity Radiation





### Carrier Type Dimensions



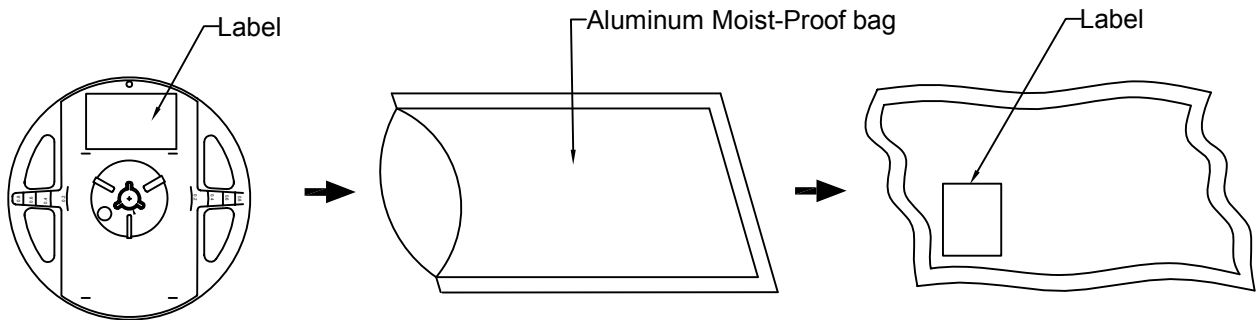

Note : The tolerances unless mentioned is  $\pm 0.1\text{mm}$ , Angle  $\pm 0.5$ . Unit=mm.

### • Packing Specifications



Part No.	Description	Quantity/Reel
LG-2835W-1-T150-D702	12.0mm tape,7"reel	2000 PCS

## Label Explanation

	LIGITEK ELECTRONICS CO., LTD.	
		
	PART :	LG-2835W-1-T150-D702
	LOT :	GS11490168
	QTY(PCS):	2000
BIN/HUE :	F55V/30K-2	VF:3.0-3.2

BIN : Luminous Flux

HUE : Chromaticity Coordinates  
(CIE\_x , CIE\_y)

VF : Forward Voltage

## Reel Dimensions

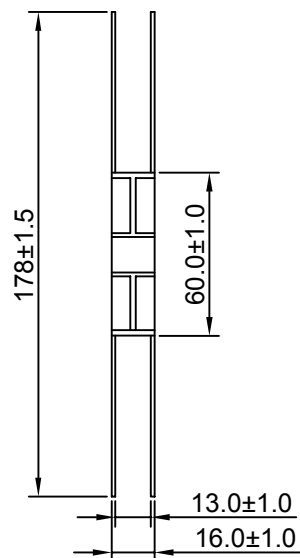
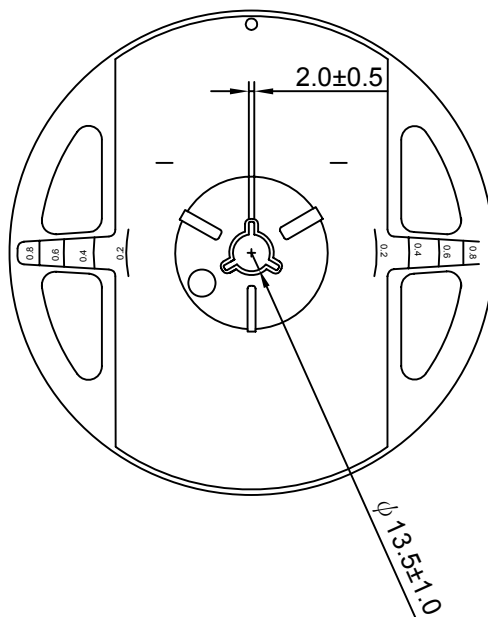

## Box Explanation

1. 4 BAG / INNER BOX

2. INNER BOX SIZE : L X W X H 23cm X 8.5cm x 26cm

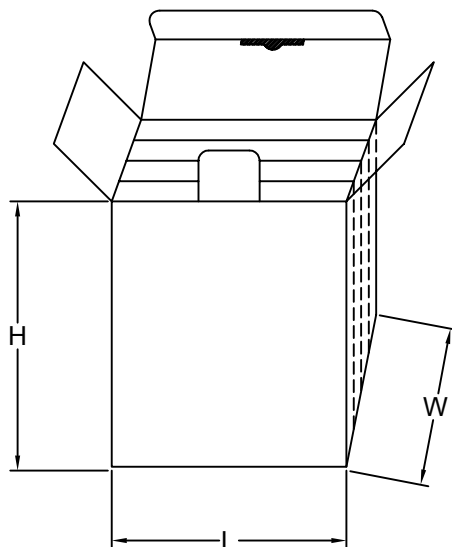

3. 10 INNER BOXES / CARTON

4. CARTON SIZE : L X W X H 58cm X 34cm x 35cm

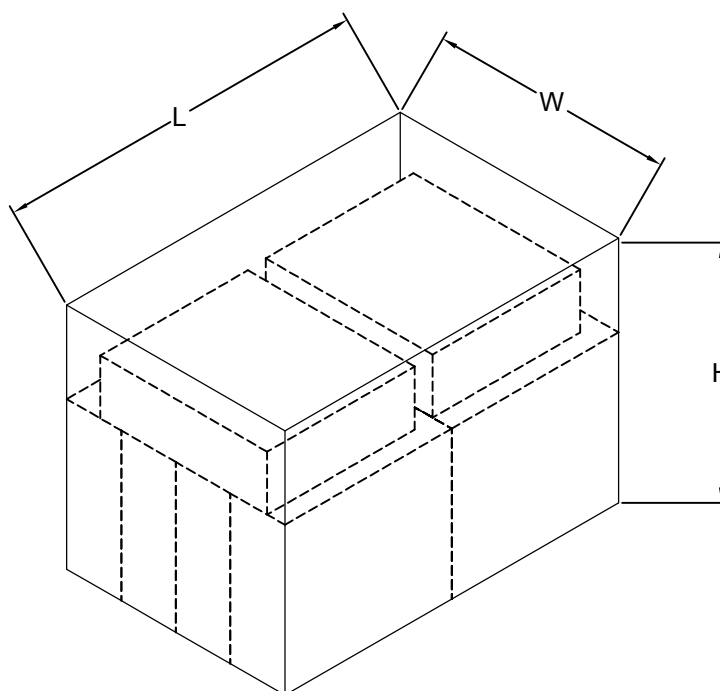

**Recommended Soldering Conditions****1. Hand Solder**

Basic spec is  $\leq 320^{\circ}\text{C}$  3 sec one time only.

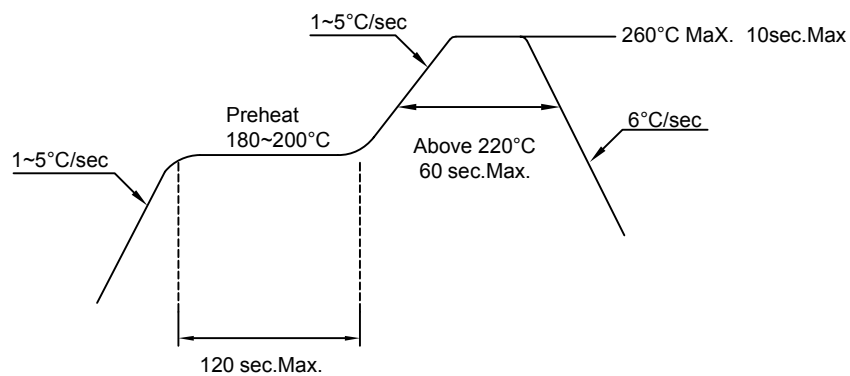
**2. PB-Free Reflow Solder****Note:**

- 1.Reflow soldering should not be done more than two times.
- 2.When soldering,do not put stress on the LEDs during heating.
- 3.After soldering,do not warp the circuit board.

**Precautions For Use:****Storage time:**

- 1.The operation of Temperatures and RH are :  $5^{\circ}\text{C}\sim 35^{\circ}\text{C}$ ,RH60%.
- 2.Once the package is opened, the products should be used within a week.  
Otherwise, they should be kept in a damp proof box with descanting agent.  
Considering the tape life, we suggest our customers to use our products within a year(from production date).
- 3.If opened more than one week in an atmosphere  $5^{\circ}\text{C} \sim 35^{\circ}\text{C}$ ,RH60%, they should be treated at  $60^{\circ}\text{C}\pm 5^{\circ}\text{C}$  for 15hrs.

**Drive Method:**

LED is a current operated device, and therefore, requires some kind of current limiting incorporated into the driver circuit. This current limiting typically takes the form of a current limiting resistor placed in series with the LED.

Consider worst case voltage variations than could occur across the current limiting resistor. The forward current should not be allowed to change by more than 40% of its desired value.

Circuit model A

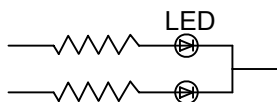

Circuit model B

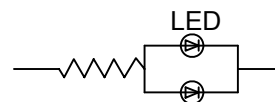

(A) Recommended circuit.

(B) The difference of brightness between LED could be found due to the VF-IF characteristics of LED.

**Cleaning:**

Use alcohol-based cleaning solvents such as isopropyl alcohol to clean the LED.

**ESD(Electrostatic Discharge):**

Static Electricity or power surge will damage the LED. Use of a conductive wrist band or anti-electrostatic glove is recommended when handling these LED. All devices, equipment and machinery must be properly grounded.

**Reliability Test:**

(1)Test items and results

Classification	Test Item	Test Condition	Sample Size
Endurance Test	Operating Life Test	1.Ta=Under Room Temperature As Per Data Sheet Maximum Rating. 2.If=150mA 3.t=1000 hrs	22
	High Temperature Storage Test	1.Ta=105°C±5°C 2.t=500 hrs	22
	Low Temperature Storage Test	1.Ta=-40°C±5°C 2.t=1000 hrs	22
	High Temperature High Humidity Storage Test	1.IR-Reflow In-Board, 2 Times 2.Ta=85°C±5°C 3.RH=90%~95% 4.t=500hrs±2hrs	22
Environmental Test	Thermal Shock Test	1.IR-Reflow In-Board,2 times 2.Ta=105°C±5°C & -40°C±5°C (30min) (30min) 3.total 100 cycles	22
	Reflow Soldering Test	1.T.Sol=260°C±5°C 2.Dwell Time= 10 Max.	22
	Temperature Cycling	1.105°C ~ 25°C ~ -40°C 30mins 15mins 30mins 2.100 Cyeles	22

(2)Criteria for judging the damage

Item	Symbol	Test Conditions	Criteria for Judgement	
			Min.	Max.
Forward Voltage	Vf	If=150mA	-	U.S.L x1.2
Reverse Current	Ir	Vr=5V	-	U.S.L x2.0
Luminous Intensity	Iv	If=150mA	L.S.L x 0.5	-

Note:

1.U.S.L.:Upper Standard Level.

2.L.S.L.:Lower Standard Level.