



LIGITEK ELECTRONICS CO.,LTD.  
Property of Ligitek Only

---

SURFACE MOUNT LED TAPE AND REEL



Lead-Free Parts

**LG-CN3535DGM-1-T350-LS13**

# DATA SHEET

DOC. NO : QW0905-LG-CN3535DGM-1-T350-LS13

REV. : A

DATE : 23 - Feb. - 2018



**Features:**

- 1.Top view LED.
2. Small package with high efficiency
- 3.Soldering methods: IR reflows soldering.
- 4.RoHS compliant
- 5.Pb Free

**Applications:**

1. LCD back light.
2. Mobile phones.
3. Indicators.
4. Switch lights.

**Device Selection Guide:**

PART NO	MATERIAL	COLOR	
		Emitted	Lens
LG-CN3535DGM-1-T350-LS13	InGaN	Green	Water Clear

## Product Nomenclature

**LG - CN 3535 DGM - 1 - T350 - LS13**

A            B            C            D            E            F            G

A	B	C	D
Title	Module	Dimension(HXW)	Color
LG: Ligitek	CN: Ceramics Aluminum Nitride	3.5 X 3.5mm	DGM: Green
E	F	G	H
Chip Modification	Test Current	Lens	Modification
1: 1 chip in 1	T350: 350mA	LS13 :LENS Type	

## Package Dimensions

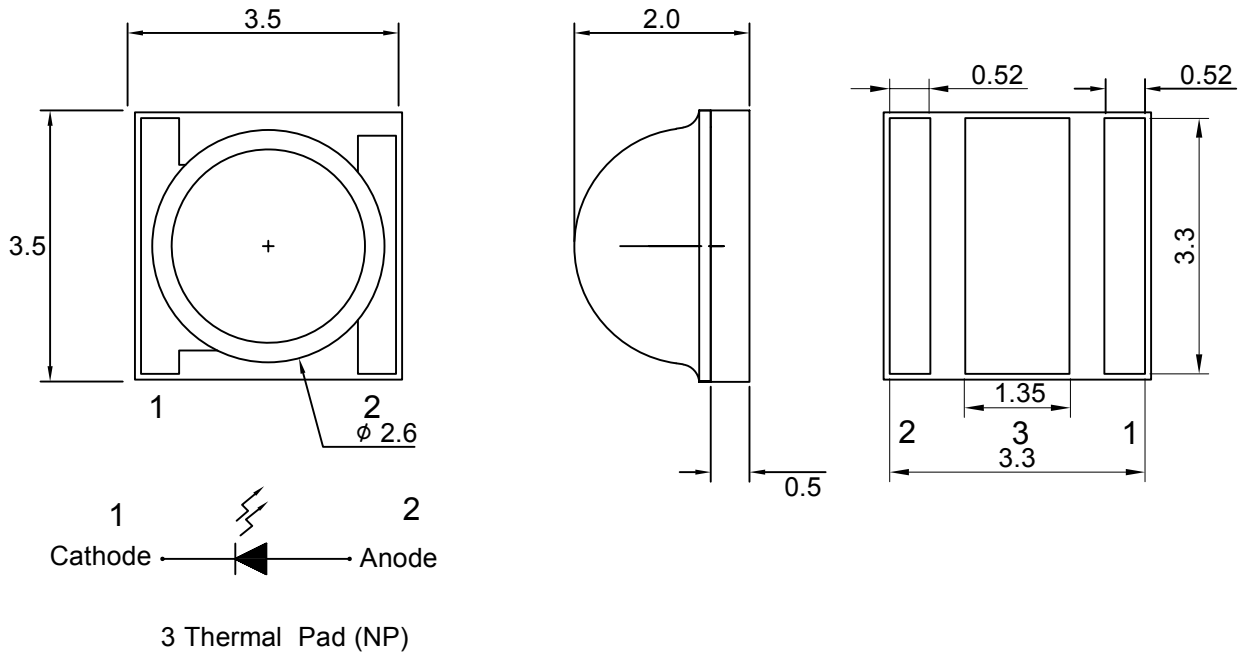

Note : 1.All dimension are in millimeter tolerance is  $\pm 0.2\text{mm}$  unless otherwise noted.  
2.Specifications are subject to change without notice.

## Recommended Soldering Pad Dimensions

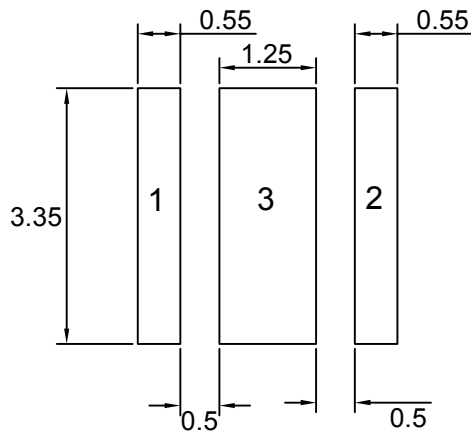

Note : The tolerances unless mentioned is  $\pm 0.1\text{mm}$ , Unit=mm.

Absolute Maximum Ratings at Ta=25°C

Parameter	Symbol	Ratings	UNIT
Power Dissipation	Pd	1.33	W
DC Forward Current	IF	350	mA
Reverse Current(VR=5V)	I <sub>r</sub>	10	μA
Peak pulse current Duty1/10@10KHz	I <sub>FP</sub>	700	mA
ESD Sensitivity	HBM 100pf/1.5 KΩ	500	V
	MM 200pf/0Ω	150	V
LED junction Temperature	T <sub>j</sub>	115	°C
Thermal resistance	R <sub>th</sub>	10	°C/W
Operating Temperature	T <sub>opr</sub>	-40 ~ +85	°C
Storage Temperature	T <sub>stg</sub>	-40 ~ +100	°C
Soldering Temperature	T <sub>p</sub>	260	°C

**Typical Electrical & Optical Characteristics (Ta=25°C)**

Parameter	Symbol	Min.	Typ.	Max.	UNIT	CONDITION
Luminous Intensity	Iv	20000	25500	----	mcd	IF=350mA
Dominant Wavelength	$\lambda_D$	519	----	531	nm	IF=350mA
Spectral Line Half Width	$\Delta \lambda$	----	36	----	nm	IF=350mA
Forward Voltage	VF	2.8	----	3.8	V	IF=350mA
Viewing Angle	2 $\theta$ 1/2	----	130	----	deg	IF=350mA

Note : 1.The forward voltage data did not including  $\pm 0.1V$  testing tolerance.

2.The luminous intensity data did not including  $\pm 15\%$  testing tolerance.

3.The dominant wavelength data did not including  $\pm 1nm$  testing tolerance.

**Luminous Intensity Classification**

BIN CODE	IV(mcd) at 350mA	
	Min.	Max.
AC-1	20000	25500
AC-2	25500	32000
AD-1	32000	40000

**Dominant Wavelength Classification**

BIN CODE	$\lambda D$ (nm) at 350mA	
	Min.	Max.
1O	519	522
1P	522	525
1Q	525	528
1R	528	531

**Forward Voltage Classification**

BIN CODE	Vf(v) at 350mA	
	Min.	Max.
1	2.8	3.0
2	3.0	3.2
3	3.2	3.4
4	3.4	3.6
5	3.6	3.8

## Typical Electro-Optical Characteristics Curve

Fig.1 Relative Intensity  
VS. Forward Current

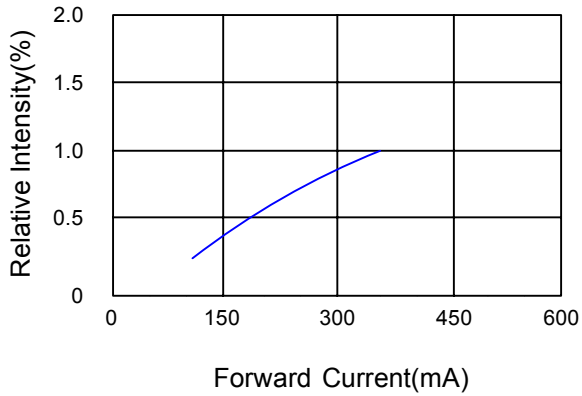

Fig.2 Forward Current  
VS. Ambient Temperature

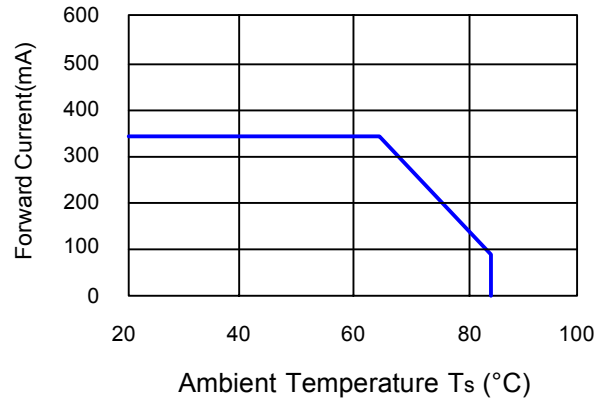

Fig.3 Relative Radiant Power  
VS. Wavelength

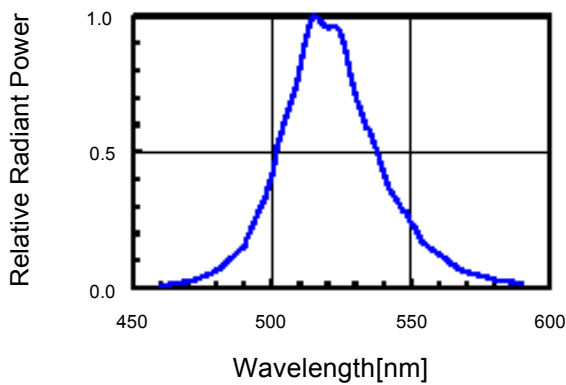

Fig.4 Forward Voltage  
VS. Forward Current

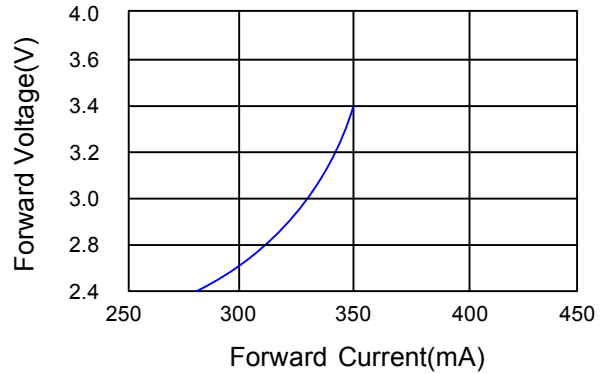
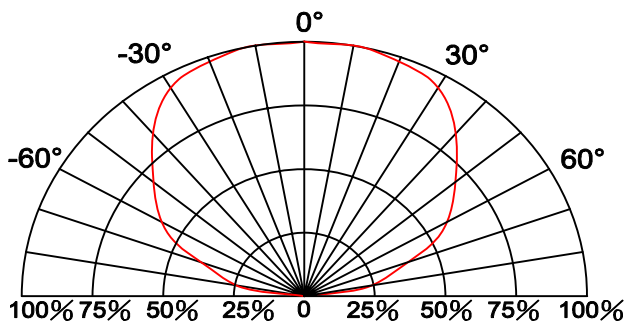
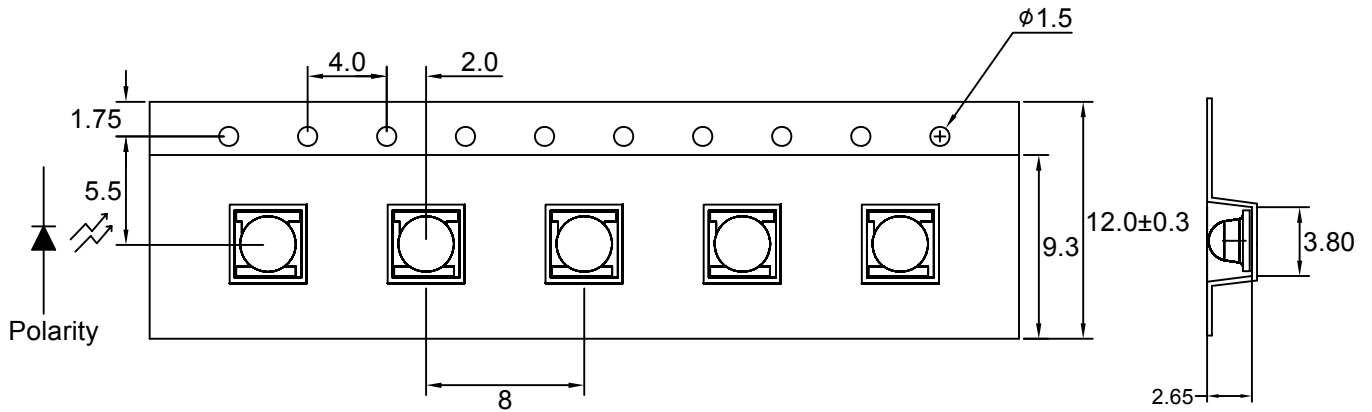

Fig.5 Directive Radiation





## Carrier Tape Dimensions







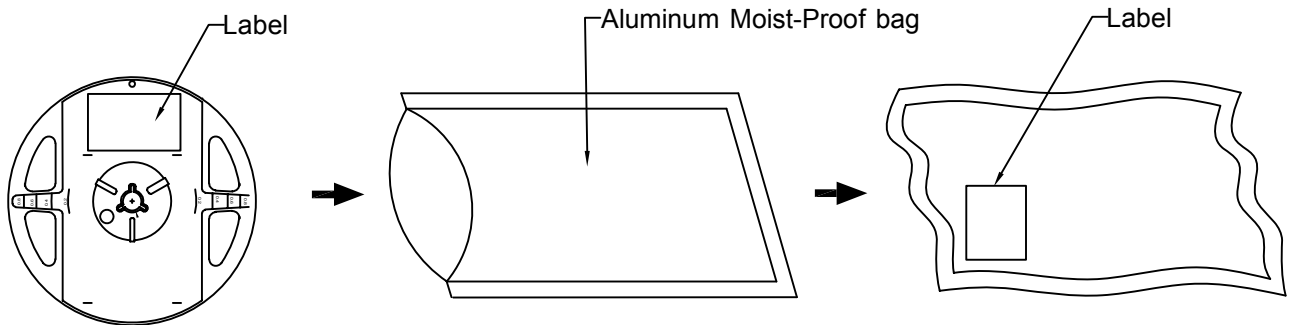

Note : The tolerances unless mentioned is  $\pm 0.1$ mm, Angle  $\pm 0.5$ . Unit=mm.

## Packing Specifications



Part No.	Description	Quantity/Reel
LG-CN3535DGM-1-T350-LS13	12.0mm tape,7"reel	500 PCS

## Label Explanation

	LIGITEK ELECTRONICS CO., LTD.	
		
	PART :	LG-CN3535DGM-1-T350-LS13
		
	LOT :	GS11580168
		
QTY(PCS):	500	
		
BIN/HUE :	AC-1/1P	VF:3.2-3.4

BIN : Luminous Intensity

HUE : Dominant Wavelength

VF : Forward Voltage

## Reel Dimensions

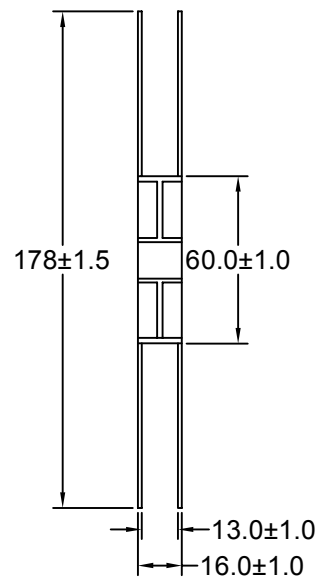
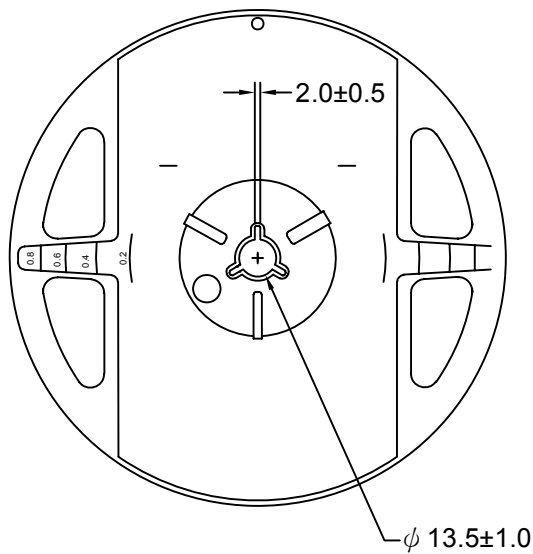

## Box Explanation

1. 4 BAG / INNER BOX
2. INNER BOX SIZE : L X W X H 23cm X 8.5cm x 26cm

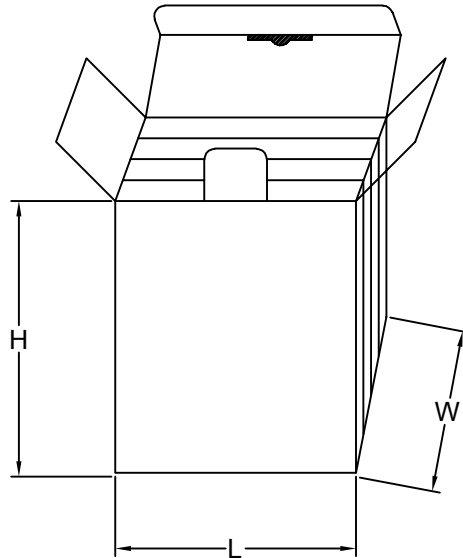

3. 10 INNER BOXES / CARTON
4. CARTON SIZE : L X W X H 58cm X 34cm x 35cm

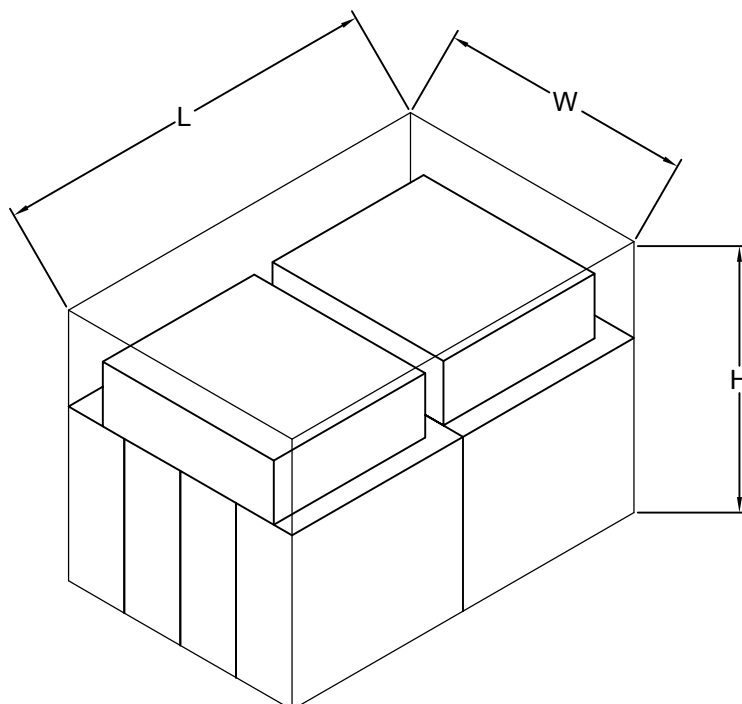

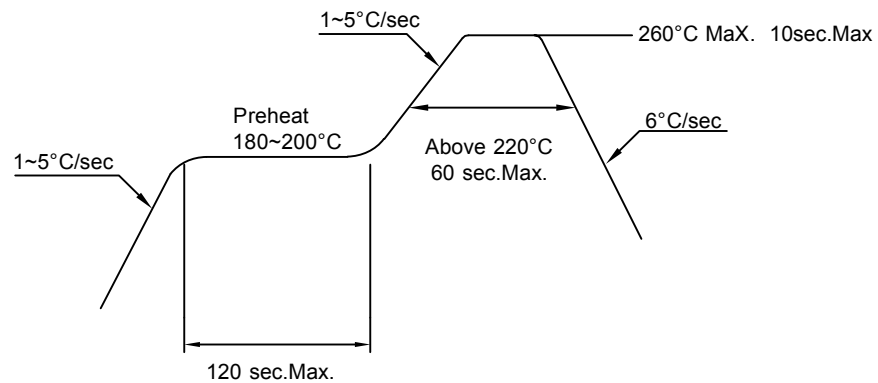
**Recommended Soldering Conditions****PB-Free Reflow Solder****Note:**

- 1.Reflow soldering should not be done more than two times.
- 2.When soldering,do not put stress on the LEDs during heating.
- 3.After soldering,do not warp the circuit board.

**Precautions For Use:****Storage time:**

1. Calculated shelf life before opening is 12 months at  $< 30^{\circ}\text{C}$  and  $< 90\%$  relative humidity (RH)
2. After bag is opened, devices which will be subjected to reflow soldering or other high temperature processes must be
  - a) Assembled within 168 hours in an environment of  $\leq 30^{\circ}\text{C} / 60\%$  RH, or
  - b) Stored at ambient of 10% RH or less
3. Devices are required baking before assembly if:
  - a) Humidity Indicator Card reads  $>10\%$  (for level 2a -5a) or  $>60\%$  (for level 2) at ambient temperature  $23\pm 5^{\circ}\text{C}$
  - b) 2.a) or 2.b) doesn't meet
4. If baking is required, devices should be baked for  $>72$  hours at  $60\pm 5^{\circ}\text{C} / 5\%$  RH. Performing baking only once, and using the baked devices within 72 hours.

MSL LEVEL 3

**Drive Method:**

LED is a current operated device, and therefore, requires some kind of current limiting incorporated into the driver circuit. This current limiting typically takes the form of a current limiting resistor placed in series with the LED.

Consider worst case voltage variations than could occur across the current limiting resistor. The forward current should not be allowed to change by more than 40% of its desired value.

Circuit model A

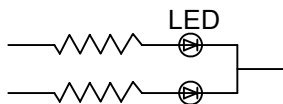

Circuit model B

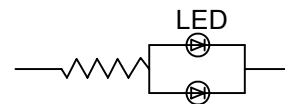

(A) Recommended circuit.

(B) The difference of brightness between LED could be found due to the VF-IF characteristics of LED.

**Cleaning:**

Use alcohol-based cleaning solvents such as isopropyl alcohol to clean the LED.

**ESD(Electrostatic Discharge):**

Static Electricity or power surge will damage the LED. Use of a conductive wrist band or anti-electrostatic glove is recommended when handling these LED. All devices, equipment and machinery must be properly grounded.

Reliability Test:

Classification	Test Item	Test Condition	Sample Size
Endurance Test	Operating Life Test	1.Ta=25°C 2.If=350mA 3.t=1000 hrs (-24hrs,+72hrs)	22
	High Temperature Storage Test	1.Ta=100°C±5°C 2.t=1000 hrs (-24hrs,+72hrs)	22
	Low Temperature Storage Test	1.Ta=-40°C±5°C 2.t=1000 hrs (-24hrs,+72hrs)	22
	High Temperature High Humidity Storage Test	1.Ta=85°C 2.RH=85% 3.t=1000hrs(-24hrs,+72hrs)	22
Environmental Test	Thermal Shock Test	1.Ta=100°C±5°C ~ -40°C±5°C 20min/ 10sec / 20min 2.total 100 cycles	22
	Temperature Cycling	1.100°C±5°C ~ -40°C±5°C 30mins / 5mins / 30mins 2.100 Cyeles	22
	IR Reflow	1.T=260°C Max. 10sec.Max. 2. 6 Min	22

## Please follow the guideline to grab LEDs

- don't touch lens with the fingers
- use tweezers to grab LED
- don't apply more than 4N of lens(400G) directly onto the lens
- don't touch lens with the tweezers

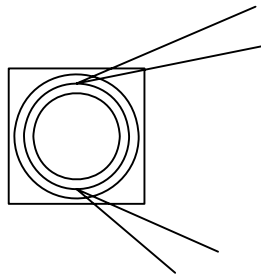

Wrong(x)

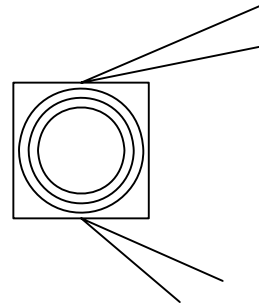

Correct(o)

## Lens cleaning

in the case where a minimal level of dirt and dust particles can not be guaranteed, a suitable cleaning solution can be applied to the lens surface

- try a gentle swabbing using a lint-free swab
- if needed, the use of lint-free swab and isopropyl alcohol used gently removes dirt from the lens
- don't use other solvents as they may directly react with the led assembly.
- don't use ultrasonic cleaning that the led will be damaged