



LIGITEK

LIGITEK ELECTRONICS CO.,LTD.
Property of Ligitek Only

SINGLE DIGIT SMD DISPLAY(0.39")



Lead-Free Parts

LSSD305/6DGM-XX

DATA SHEET

DOC. NO : QW0905-LSSD305/6DGM-XX

REV. : A

DATE : 26 - May. - 2009



Package Dimensions

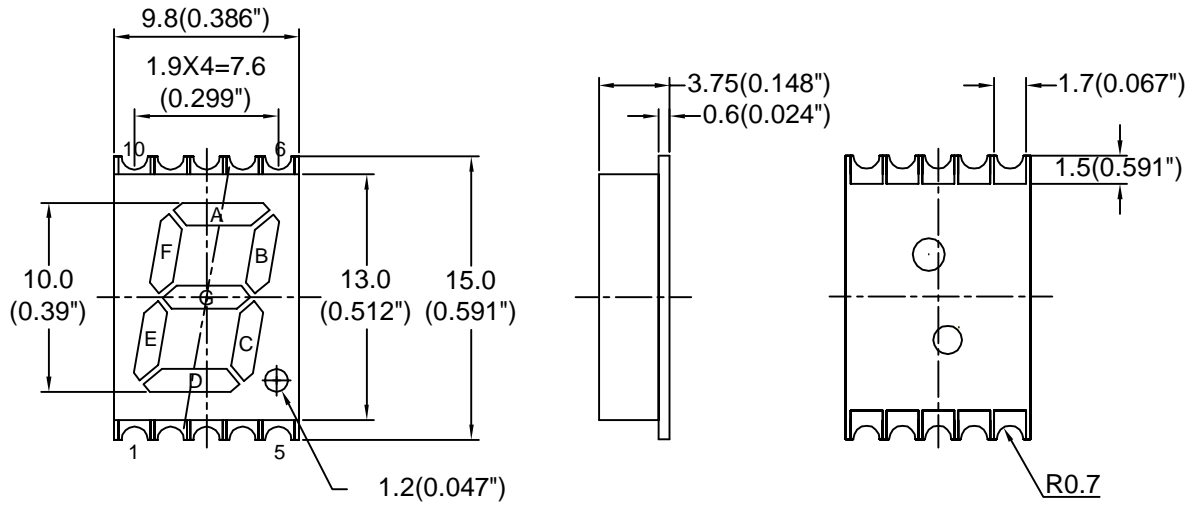

Note : 1.All dimension are in millimeters and (Inch) tolerance is $\pm 0.25\text{mm}$ unless otherwise noted.
2.Specifications are subject to change without notice.

Recommended Soldering Pad Dimensions

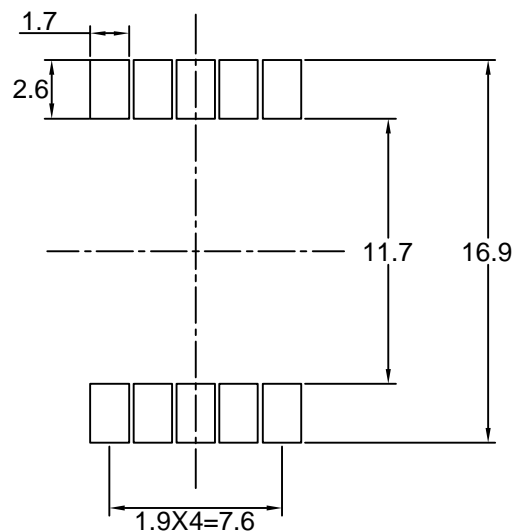

Note : The tolerances unless mentioned is $\pm 0.1\text{mm}$.



Internal Circuit Diagram

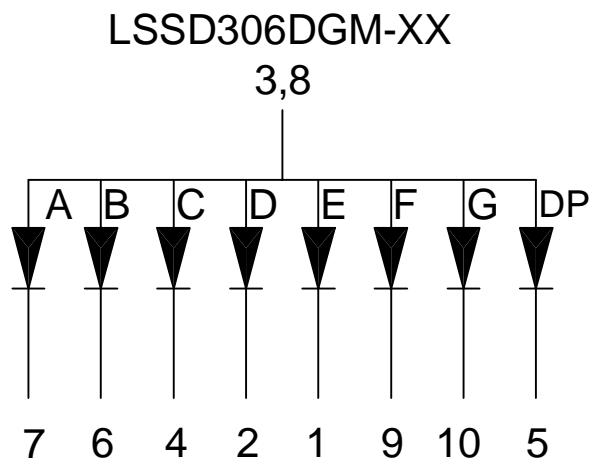
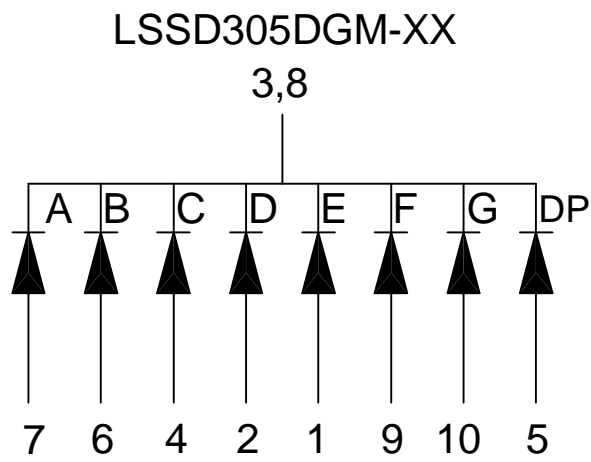



Electrical Connection

PIN NO.	LSSD305DGM-XX	PIN NO.	LSSD306DGM-XX
1	Anode E	1	Cathode E
2	Anode D	2	Cathode D
3	Common Cathode	3	Common Anode
4	Anode C	4	Cathode C
5	Anode DP	5	Cathode DP
6	Anode B	6	Cathode B
7	Anode A	7	Cathode A
8	Common Cathode	8	Common Anode
9	Anode F	9	Cathode F
10	Anode G	10	Cathode G



Absolute Maximum Ratings at Ta=25

Parameter	Symbol	Ratings	UNIT
Power Dissipation Per Chip	PD	80	mW
Peak Forward Current Per Chip Duty 1/10@10KHz	IFP	100	mA
Forward Current Per Chip	IF	20	mA
Reverse Current Per Chip @5V	Ir	50	μA
Electrostatic Discharge	ESD	500	V
Operating Temperature	Topr	-40 ~ +85	
Storage Temperature	Tstg	-40 ~ +85	

Part Selection And Application Information(Ratings at 25)

PART NO	CHIP		common cathode or anode	D (nm)	(nm)	Electrical				IV-M
	Material	Emitted				Vf(v)		IV(mcd)		
						Typ.	Max.	Min.	Typ.	
LSSD305DGM-XX	InGaN/SiC	Green	Common Cathode	525	36	3.5	4.0	50	91	2:1
LSSD306DGM-XX			Common Anode							

Note : 1.The forward voltage data did not including ±0.1V testing tolerance.
 2. The luminous intensity data did not including ±15% testing tolerance.

**Test Condition For Each Parameter**

Parameter	Symbol	Unit	Test Condition
Forward Voltage Per Chip	V _f	volt	I _f =20mA
Luminous Intensity Per Chip	I _v	mcd	I _f =10mA
Dominant Wavelegth	D	nm	I _f =20mA
Spectral Line Half-Width		nm	I _f =20mA
Reverse Current Any Chip	I _r	μ A	V _r =5V
Luminous Intensity Matching Ratio	IV-M		



Typical Electro-Optical Characteristics Curve

DGM CHIP

Fig.1 Forward current vs. Forward Voltage

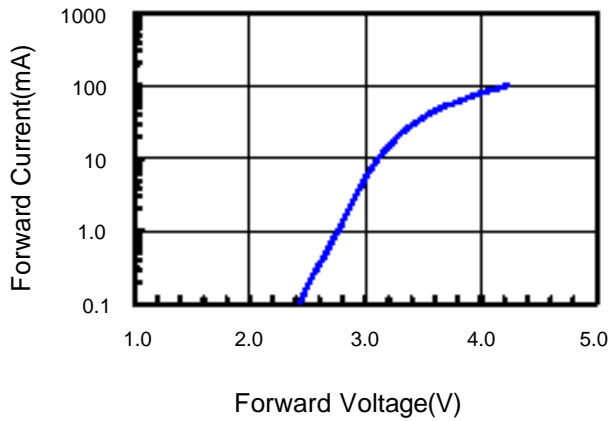

Fig.2 Relative Intensity vs. Forward Current

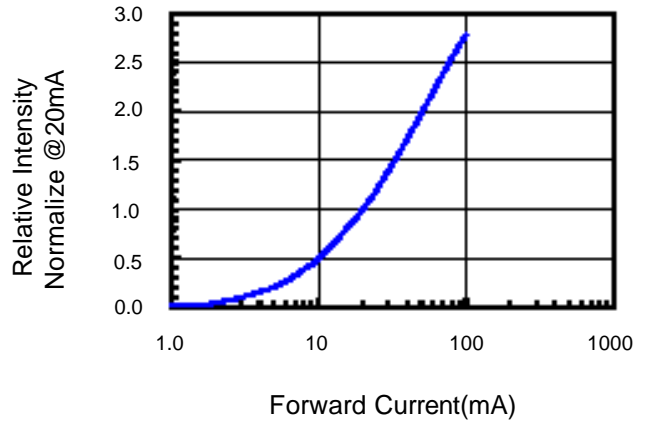

Fig.3 Forward Voltage vs. Temperature

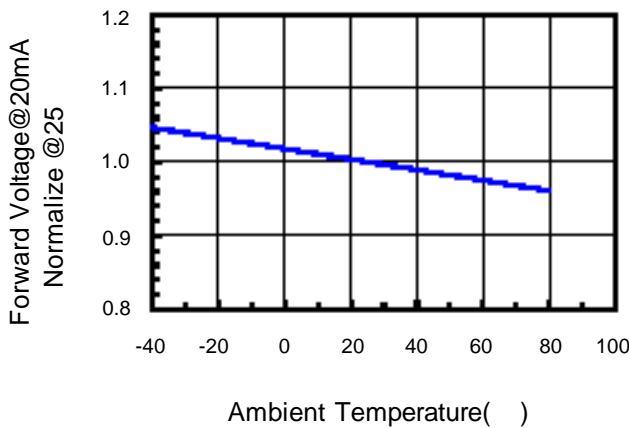

Fig.4 Relative Intensity vs. Temperature

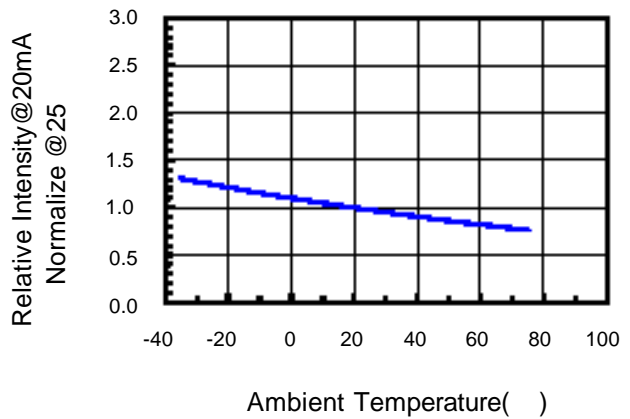
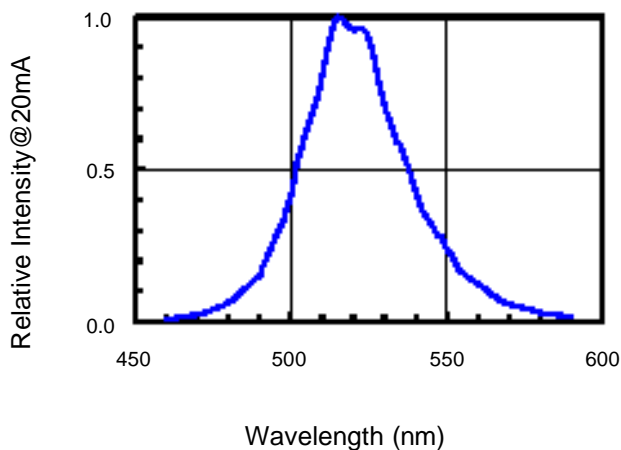

Fig.5 Relative Intensity vs. Wavelength





LIGITEK

LIGITEK ELECTRONICS CO.,LTD.
Property of Ligitek Only

PART NO. LSSD305/6DGM-XX

Page 7/9

Carrier Type Dimensions

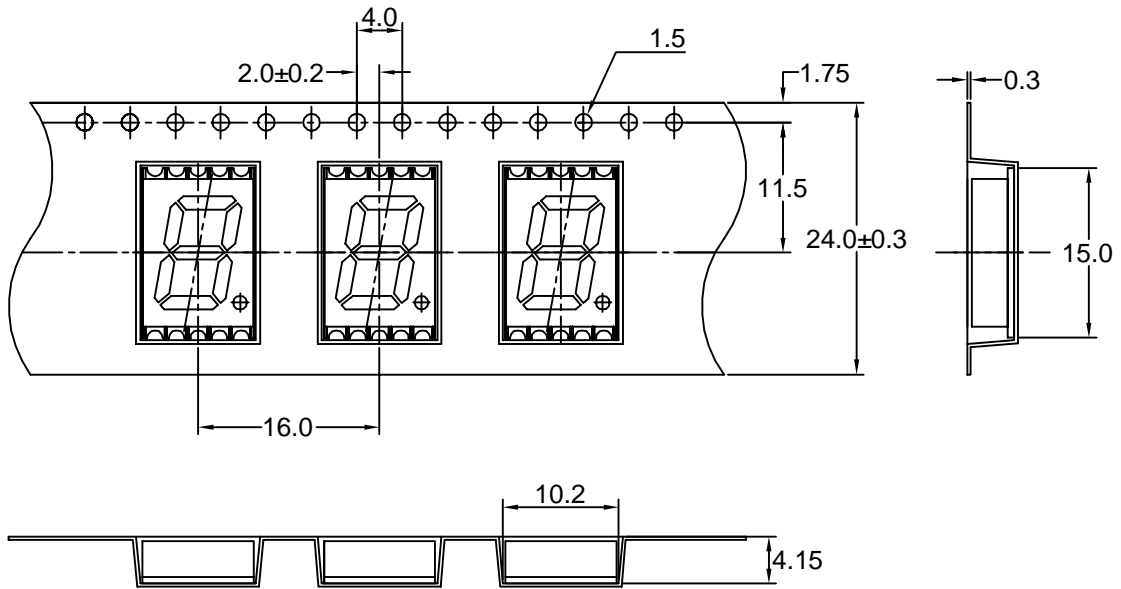

Note : The tolerances unless mentioned is ± 0.1 mm, Angle ± 0.5 . Unit=mm.

Package Dimensions

1000PCS / REEL

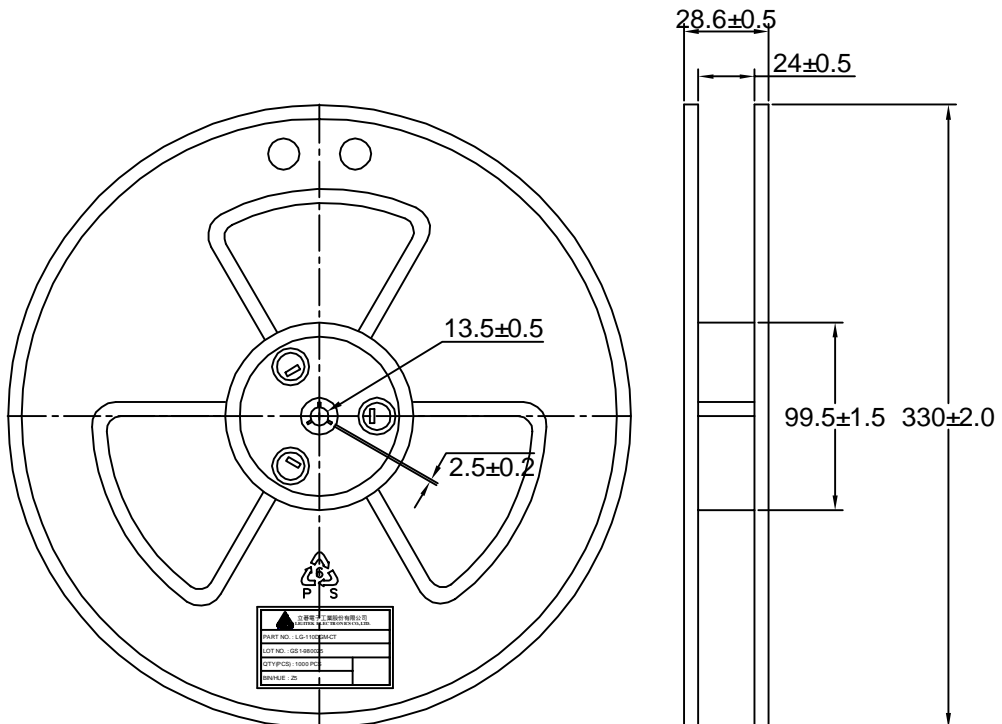



Recommended Soldering Conditions

1. Hand Solder :

Soldering Iron:30W Max

Temperature 280°C Max

Soldering Time:3 Seconds Max(One time only)

Distance:2mm Min(From solder joint to case)

2. PB-Free Reflow Solder

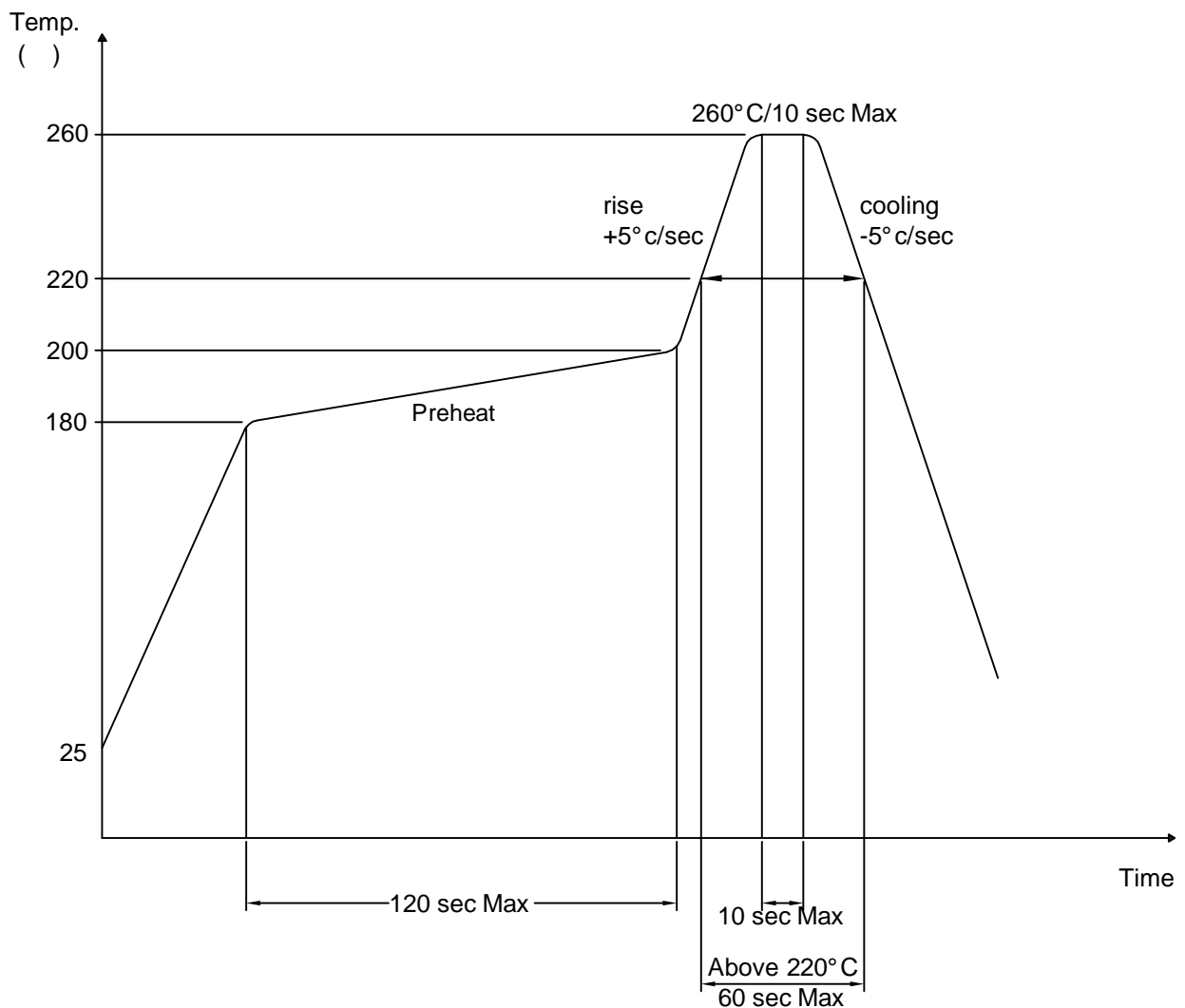

Reflow Soldering should not be done more than two times.



Reliability Test:

Classification	Test Item	Test Condition
Endurance Test	Operating Life Test	1.Ta=Under Room Temperature As Per Data Sheet Maximum Rating. 2.If=10mA 3.t=1000 hrs (-24hrs, +72hrs)
	High Temperature Storage Test	1.Ta=105 ±5 2.t=1000 hrs (-24hrs, +72hrs)
	Low Temperature Storage Test	1.Ta=-40 ±5 2.t=1000 hrs (-24hrs, +72hrs)
	High Temperature High Humidity Storage Test	1.Ta=65 ±5 2.RH=90%~95% 3.t=1000hrs ±2hrs
Environmental Test	Thermal Shock Test	1.Ta=105 ±5 & -40 ±5 (10min) (10min) 2.total 300 cycles
	Solderability Test	1.T.Sol=235 ±5 2.Immersion time 2 ±0.5sec 3.Coverage 95% of the dipped surface
	Temperature Cycling	1.105 ~ 25 ~ -55 ~ 25 30mins 5mins 30mins 5mins 2.10 Cyeles
	IR Reflow	1.T=260°C Max. 10sec.Max. 2. 6 Min