



LIGITEK ELECTRONICS CO.,LTD.
Property of Ligitek Only

LED SMD



Lead-Free Parts

LG-150HY-CT-08

DATA SHEET

DOC. NO : QW0905-LG-150HY-CT-08

REV. : C

DATE : 27 - May. - 2016



Features:

1. Package in 8.0mm carrier tape on 7" diameter reel.
2. Compatible with automatic placement equipment.
3. Compatible with reflow solder process.

Descriptions:

1. The LG-150 SMD Taping is much smaller than lead frame type components, thus enable smaller board size, higher packing density, reduced storage space and finally smaller equipment to be obtained.
2. Besides, lightweight makes them ideal for miniature applications. etc.

Applications:

1. Automotive : backlighting in dashboard and switch.
2. Telecommunication : indicator and backlighting in telephone and fax.
3. Flat backlight for LCD, switch and symbol
4. General use.

Device Selection Guide:

| PART NO | MATERIAL | COLOR | |
|----------------|----------|---------|-------------|
| | | Emitted | Lens |
| LG-150HY-CT-08 | AlGaInP | Yellow | Water Clear |

Package Dimensions

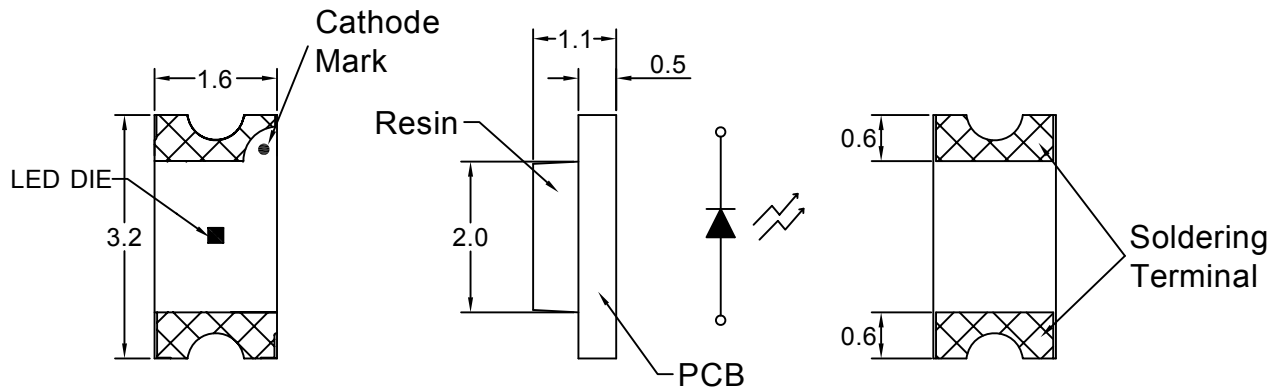

Note : 1.All dimension are in millimeter tolerance is $\pm 0.1\text{mm}$ unless otherwise noted.
 2.Specifications are subject to change without notice.

Recommended Soldering Pad Dimensions

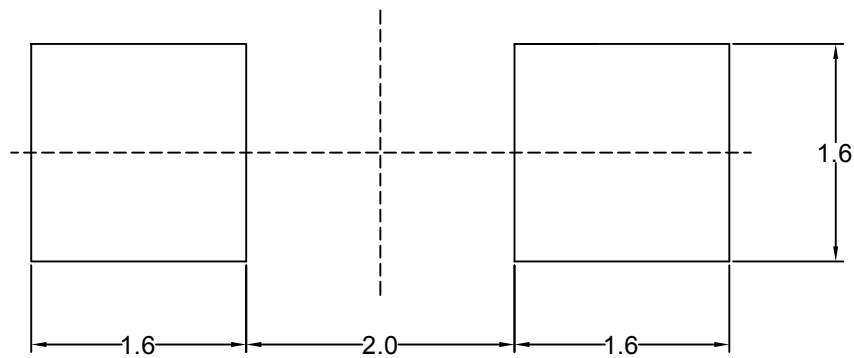

Note : The tolerances unless mentioned is $\pm 0.1\text{mm}$, Angle ± 0.5 . Unit=mm.

Absolute Maximum Ratings at Ta=25°C

| Parameter | Symbol | Ratings | UNIT |
|---|--------|-------------|------|
| Power Dissipation | PD | 65 | mW |
| Peak Forward Current Duty 1/11@10KHz | IFP | 60 | mA |
| Forward Current | IF | 25 | mA |
| Reverse Current @5V | Ir | 10 | μA |
| Electrostatic Discharge | ESD | 2000 | V |
| Operating Temperature | Topr | -40 ~ + 85 | °C |
| Storage Temperature | Tstg | -40 ~ + 100 | °C |

Typical Electrical & Optical Characteristics (Ta=25°C)

| Items | Symbol | Min. | Typ. | Max. | UNIT | CONDITION |
|--------------------------|----------------|------|------|------|------|-----------|
| Luminous Intensity | Iv | 80 | 125 | ---- | mcd | IF=20mA |
| Dominant Wavelength | λD | ---- | 595 | ---- | nm | IF=20mA |
| Spectral Line Half-Width | Δλ | ---- | 15 | ---- | nm | IF=20mA |
| Forward Voltage | V _F | 1.7 | ---- | 2.6 | V | IF=20mA |
| Viewing Angle | 2θ 1/2 | ---- | 140 | ---- | deg | IF=20mA |

Note : 1.The forward voltage data did not including ±0.1V testing tolerance.
 2. The luminous intensity data did not including ±15% testing tolerance.
 3.The dominant wavelength data did not including ±1nm testing tolerance.

Luminous Intensity Classification

| BIN CODE | Iv(mcd) at 20mA | |
|----------|-----------------|------|
| | Min. | Max. |
| Q | 80 | 125 |
| R | 125 | 200 |
| S | 200 | 320 |
| T | 320 | 500 |

Dominant Wavelength Classification

| BIN CODE | λD (nm) at 20mA | |
|----------|--------------------------|------|
| | Min. | Max. |
| 17 | 589 | 592 |
| 18 | 592 | 595 |
| 19 | 595 | 598 |
| 20 | 598 | 600 |

Typical Electro-Optical Characteristics Curve

HY CHIP

Fig.1 Forward current vs. Forward Voltage

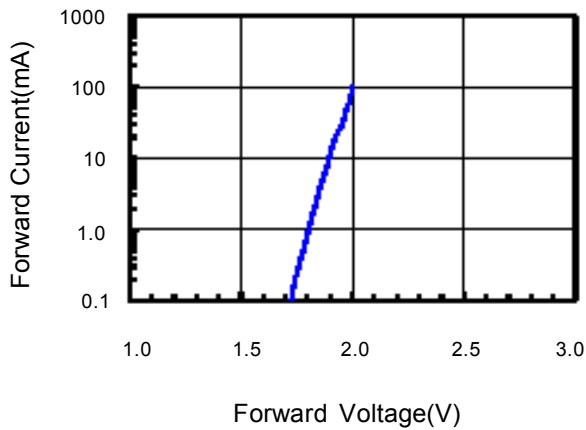

Fig.2 Relative Intensity vs. Forward Current

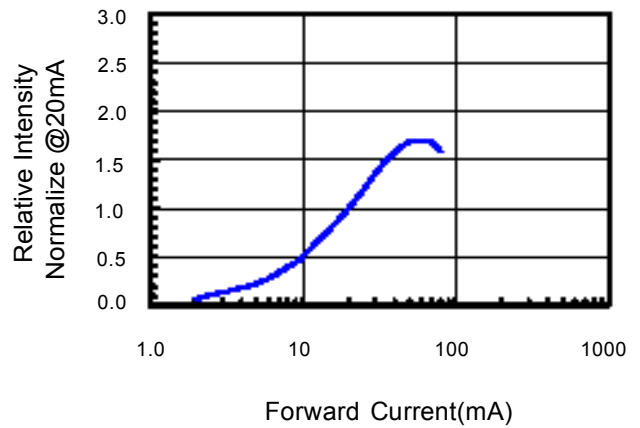

Fig.3 Forward Current vs. Temperature

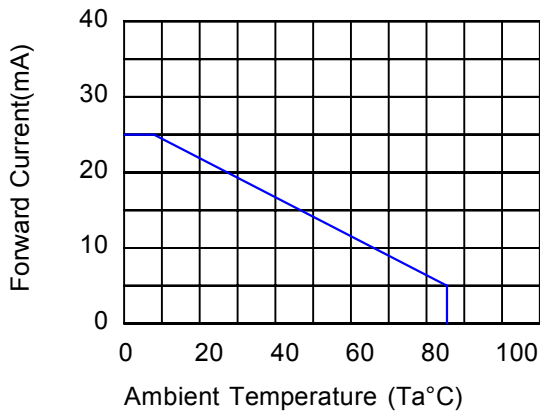

Fig.4 Relative Intensity vs. Temperature

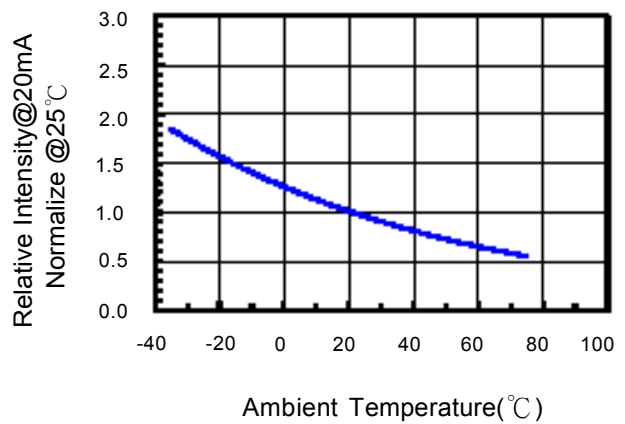

Fig.5 Relative Intensity vs. Wavelength

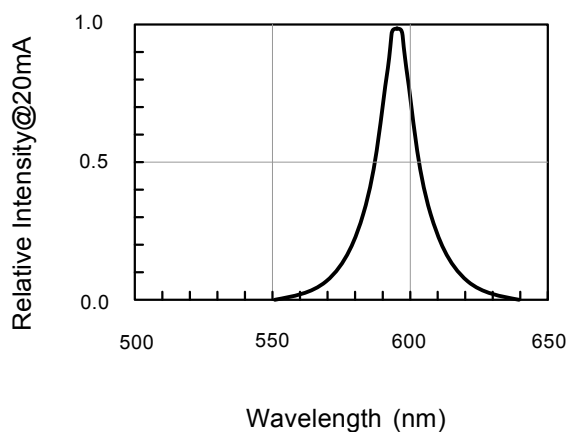
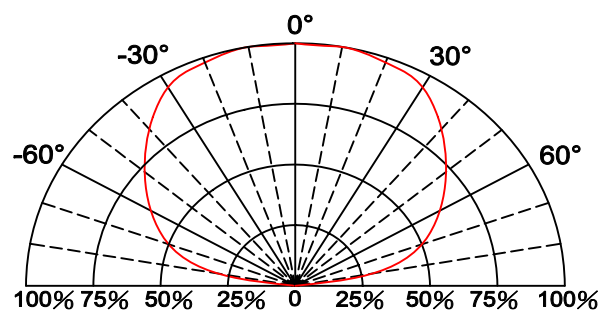
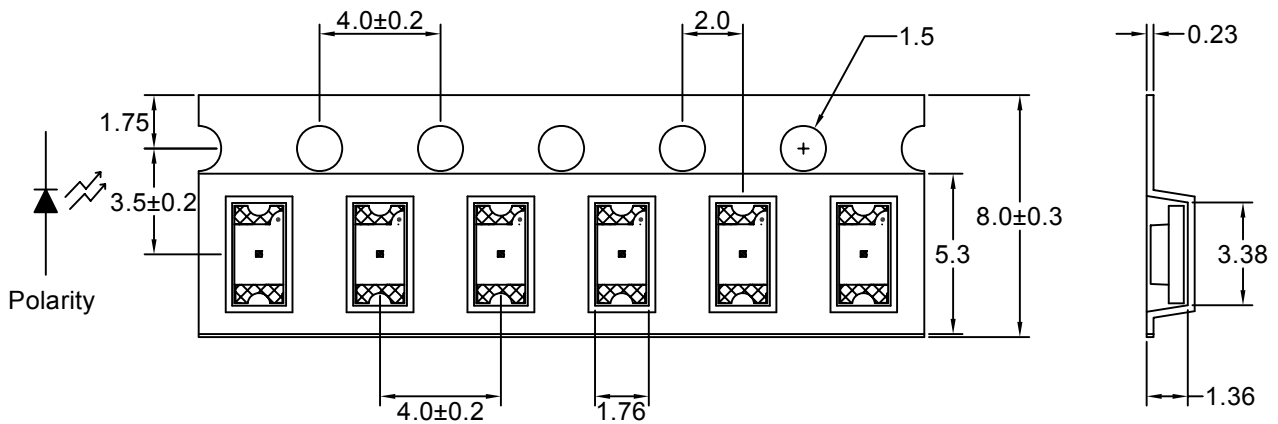

Fig.6 Directive Radiation



Carrier Type Dimensions







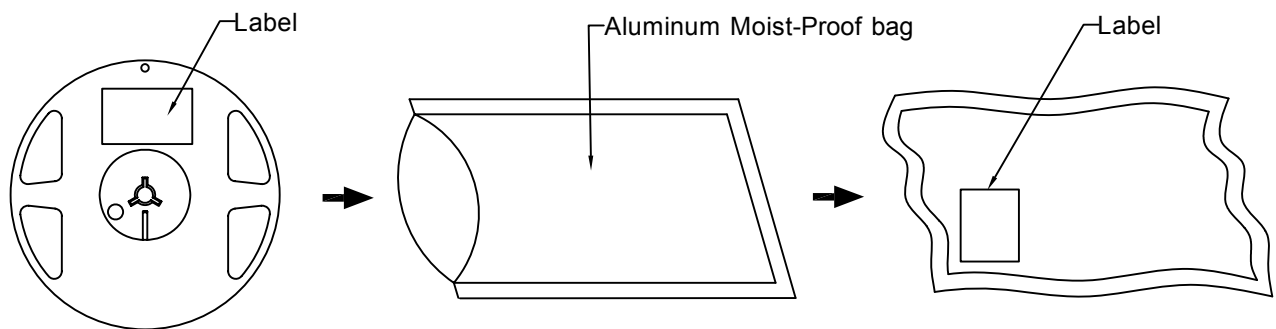

Note : The tolerances unless mentioned is ± 0.1 mm, Angle ± 0.5 . Unit=mm.

• Packing Specifications



| Part No. | Description | Quantity/Reel |
|----------------|-------------------|---------------|
| LG-150HY-CT-08 | 8.0mm tape,7"reel | 3000 devices |

Label Explanation

| | | |
|---|-------------------------------|---|
|  | LIGITEK ELECTRONICS CO., LTD. | |
| PART : | LG-150HY-CT-08 |  |
| LOT : | GS11560168 |  |
| QTY(PCS): | 3000 |  |
| BIN/HUE : | R/18 |   |
| | | VF:1.8-2.0 |

BIN : Luminous Intensity

HUE : Dominant Wavelength

VF : Forward Voltage

Reel Dimensions

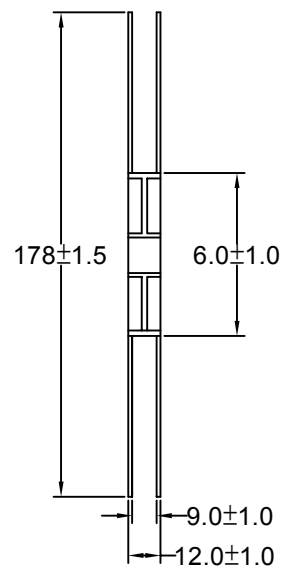
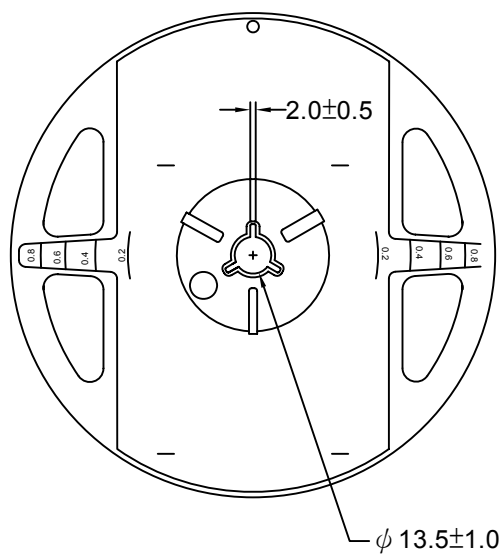

Box Explanation

- 1. 5 BAG / INNER BOX
- 2. INNER BOX SIZE : L X W X H 23cm X 8.5cm x 26cm

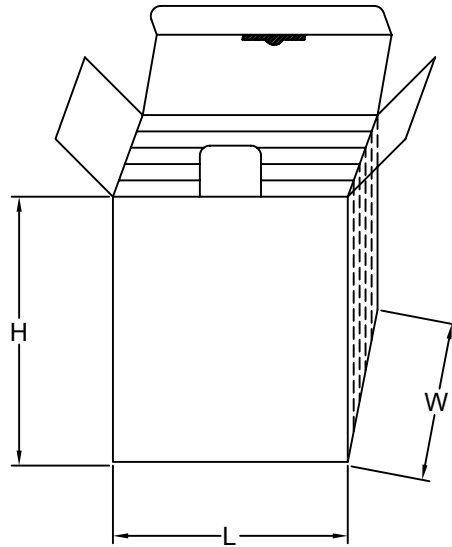

- 3. 10 INNER BOXES / CARTON
- 4. CARTON SIZE : L X W X H 58cm X 34cm x 35cm

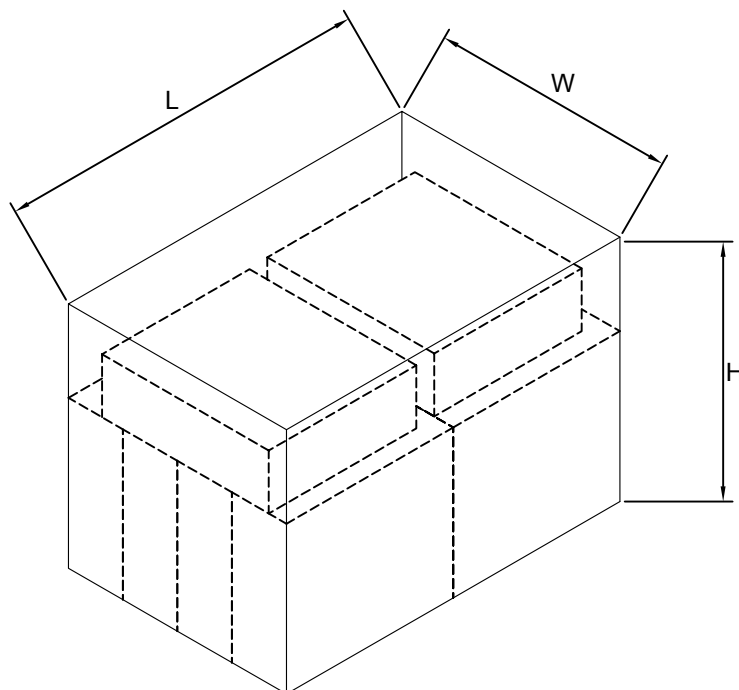

Recommended Soldering Conditions**1. Hand Solder**

Basic spec is $\leq 280^{\circ}\text{C}$ 3 sec one time only.

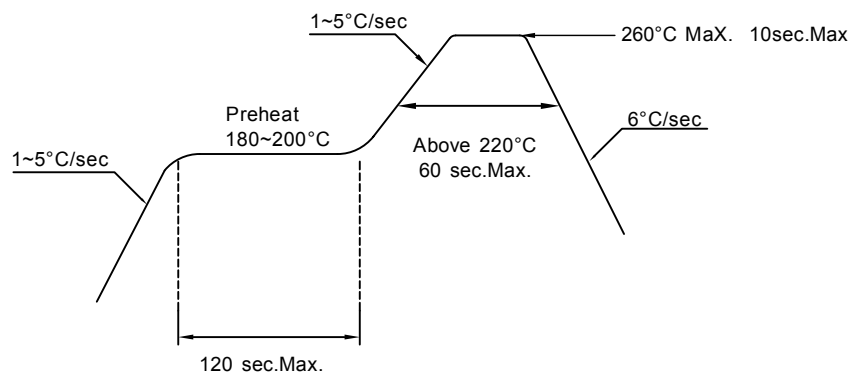
2. PB-Free Reflow Solder**Note:**

- 1.Reflow soldering should not be done more than two times.
- 2.When soldering,do not put stress on the LEDs during heating.
- 3.After soldering,do not warp the circuit board.

Precautions For Use:**Storage time:**

1. Calculated shelf life before opening is 18 months at $< 30^{\circ}\text{C}$ and $< 90\%$ relative humidity (RH)
2. After bag is opened, devices which will be subjected to reflow soldering or other high temperature processes must be
 - a) Assembled within one years in an environment of $\leq 30^{\circ}\text{C} / 60\%$ RH, or
 - b) Stored at ambient of 10% RH or less
3. Devices are required baking before assembly if:
 - a) Humidity Indicator Card reads $>10\%$ (for level 2a -5a) or $>60\%$ (for level 2) at ambient temperature $23\pm 5^{\circ}\text{C}$
 - b) 2.a) or 2.b) doesn't meet
4. If baking is required, devices should be baked for >24 hours at $60\pm 5^{\circ}\text{C}$. Performing baking only once, and using the baked devices within 72 hours..

Drive Method:

LED is a current operated device, and therefore, requires some kind of current limiting incorporated into the driver circuit. This current limiting typically takes the form of a current limiting resistor placed in series with the LED.

Consider worst case voltage variations than could occur across the current limiting resistor. The forward current should not be allowed to change by more than 40% of its desired value.

Circuit model A

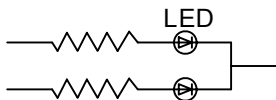

Circuit model B

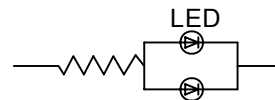

(A) Recommended circuit.

(B) The difference of brightness between LED could be found due to the VF-IF characteristics of LED.

Cleaning:

Use alcohol-based cleaning solvents such as isopropyl alcohol to clean the LED.

ESD(Electrostatic Discharge):

Static Electricity or power surge will damage the LED. Use of a conductive wrist band or anti-electrostatic glove is recommended when handling these LED. All devices, equipment and machinery must be properly grounded.

Reliability Test:

| Classification | Test Item | Test Condition | Sample Size |
|--------------------|---|--|-------------|
| Endurance Test | Operating Life Test | 1.Ta=25°C 2.If=20mA 3.t=1000 hrs (-24hrs,+72hrs) | 22 |
| | High Temperature Storage Test | 1.Ta=100°C±5°C 2.t=1000 hrs (-24hrs,+72hrs) | 22 |
| | Low Temperature Storage Test | 1.Ta=-40°C±5°C 2.t=1000 hrs (-24hrs,+72hrs) | 22 |
| | High Temperature High Humidity Storage Test | 1.Ta=85°C 2.RH=85% 3.t=1000hrs(-24hrs,+72hrs) | 22 |
| Environmental Test | Thermal Shock Test | 1.Ta=100°C±5°C ~ -40°C±5°C 20min/ 10sec / 20min 2.total 100 cycles | 22 |
| | Temperature Cycling | 1.100°C±5°C ~ -40°C±5°C 30mins / 5mins / 30mins 2.100 Cyeles | 22 |
| | IR Reflow | 1.T=260°C Max. 10sec.Max. 2. 6 Min | 22 |