

LED SMD



Lead-Free Parts

**LG-170HRF/WK-DT-A01**

**DATA SHEET**

DOC. NO : QW0905-LG-170HRF/WK-DT-A01\_A

REV. : A

DATE : 02 - Mar. - 2017



### Features:

1. Package in 8.0mm carrier tape on 7" diameter reel.
2. Compatible with automatic placement equipment.
3. Compatible with reflow solder process.

### Descriptions:

1. The LG-170 SMD Taping is much smaller than lead frame type components, thus enable smaller board size, higher packing density, reduced storage space and finally smaller equipment to be obtained.
2. Besides, lightweight makes them ideal for miniature applications. etc.

### Applications:

1. Automotive : backlighting in dashboard and switch.
2. Telecommunication : indicator and backlighting in telephone and fax.
3. Flat backlight for LCD, switch and symbol
4. General use.

### Device Selection Guide:

PART NO	MATERIAL	COLOR	
		Emitted	Lens
LG-170HRF/WK-DT-A01	AlGaInP	Red	Yellow Diffused
	InGaN	White	

## Package Dimensions

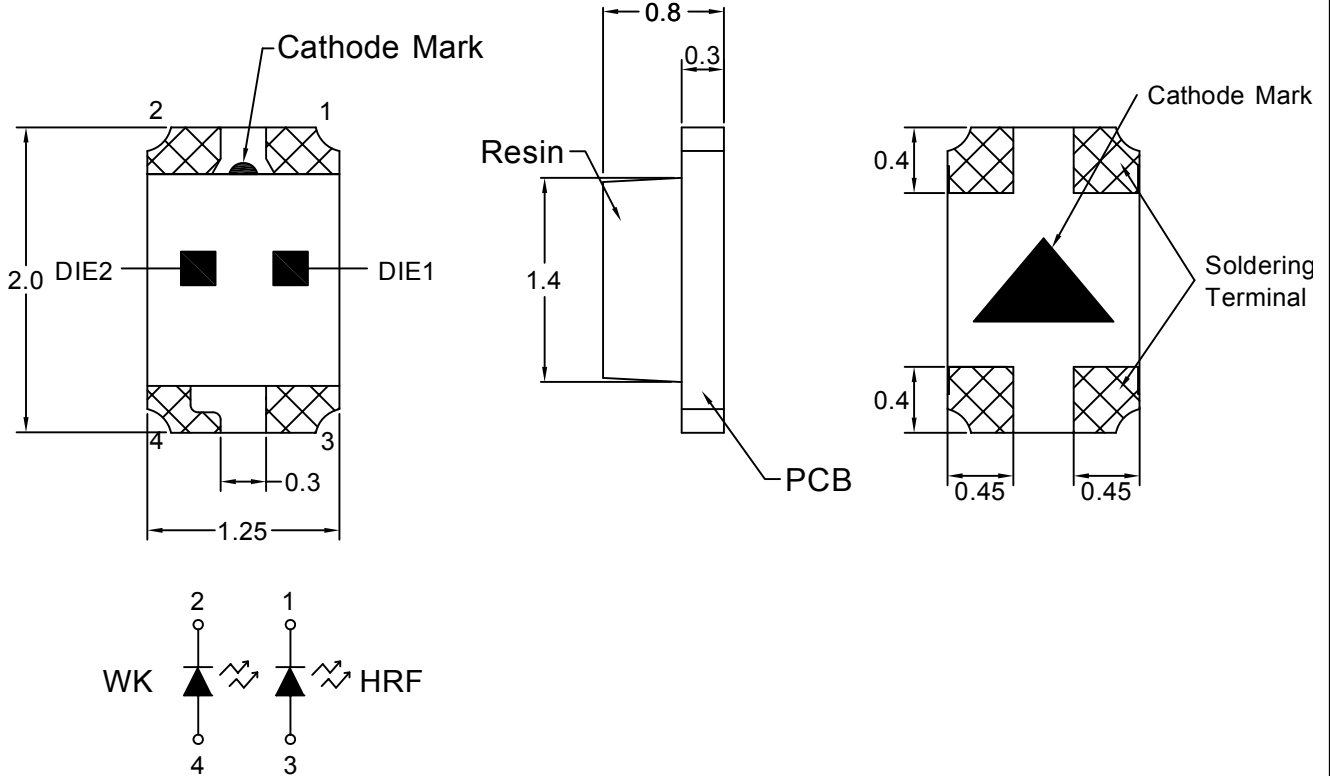

Note : 1.All dimension are in millimeter tolerance is  $\pm 0.1\text{mm}$  unless otherwise noted.  
2.Specifications are subject to change without notice.

## Recommended Soldering Pad Dimensions

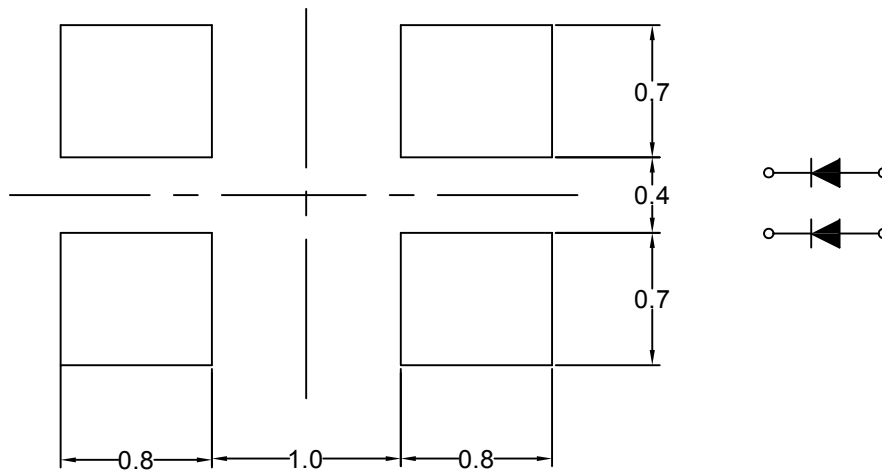

Note : The tolerances unless mentioned is  $\pm 0.1\text{mm}$ , Angle  $\pm 0.5$ . Unit=mm.

### Absolute Maximum Ratings

Parameter	Symbol	Ratings		UNIT
		HRF	WK	
Power Dissipation*	PD	60	72	mW
Peak Forward Current Duty 1/10@10KHz*	IFP	60	100	mA
Forward Current*	IF	25	20	mA
Reverse Current @5V*	Ir	10	50	μA
Electrostatic Discharge*	ESD	2000	500	V
Operating Temperature	Topr	-40 ~ + 85		°C
Storage Temperature	Tstg	-40 ~ +100		°C

\* Ambient test condition : TA=25 °C

### Typical Electrical & Optical Characteristics (Ta=25°C)

Items	Symbol	Min.	Typ.	Max.	UNIT	CONDITION	
Luminous Intensity	Iv	HRF	32	----	80	mcd	IF=20mA
		WK	200	----	500		
Dominant Wavelength	λD	HRF	624	----	633	nm	IF=20mA
Chromaticity Coordinates	X	WK	0.31	----	0.34	----	IF=20mA
	Y		0.30	----	0.385		
Spectral Line Half-Width	Δλ	HRF	----	20	----	nm	IF=20mA
		WK	----	20	----		
Forward Voltage	VF	HRF	1.5	----	2.4	V	IF=20mA
		WK	2.8	----	3.6		
Viewing Angle	2θ 1/2	HRF	----	140	----	deg	IF=20mA
		WK	----	140	----		

Note : 1.The forward voltage data did not including ±0.1V testing tolerance.  
2. The luminous intensity data did not including ±15% testing tolerance.  
3.The dominant wavelength data did not including ±1nm testing tolerance

### Luminous Intensity Classification

BIN CODE		Iv(mcd) at 20mA	
		Min.	Max.
HRF	N	32	50
	P	50	80

BIN CODE		Iv(mcd) at 20mA	
		Min.	Max.
WK	S	200	320
	T	320	500

### Dominant Wavelength Classification

BIN CODE		$\lambda D$ (nm) at 20mA	
		Min.	Max.
HRF	29	624	627
	30	627	630
	31	630	633

### CIE Chromaticity Diagram

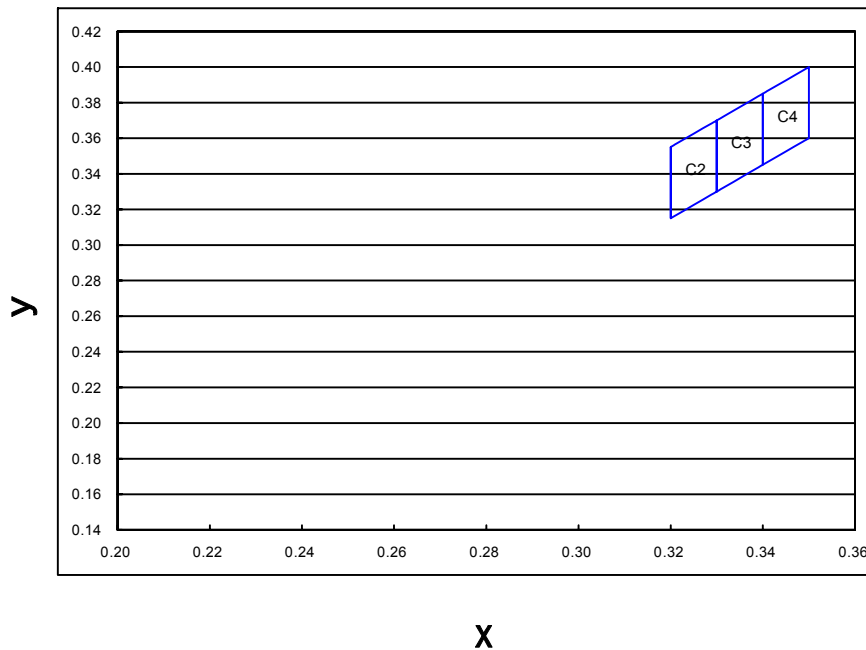

### Chromaticity Coordinates Specifications For Bin Grading

Color Coordiante at20mA								
BIN CODE	1		2		3		4	
	x	y	x	y	x	y	x	y
C2	0.32	0.355	0.32	0.315	0.33	0.33	0.33	0.37
C3	0.33	0.37	0.33	0.33	0.34	0.345	0.34	0.385
C4	0.34	0.385	0.34	0.345	0.35	0.36	0.35	0.4

## Typical Electro-Optical Characteristics Curve

### HRF CHIP

Fig.1 Forward current vs. Forward Voltage

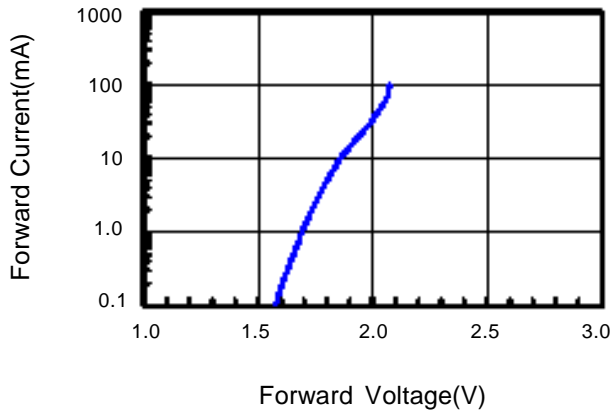

Fig.2 Relative Intensity vs. Forward Current

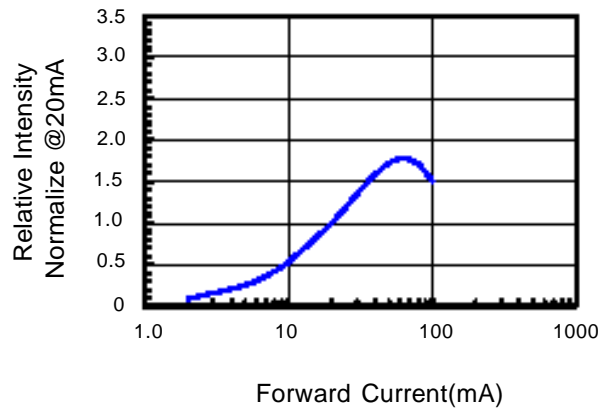

Fig.3 Forward Current vs. Temperature

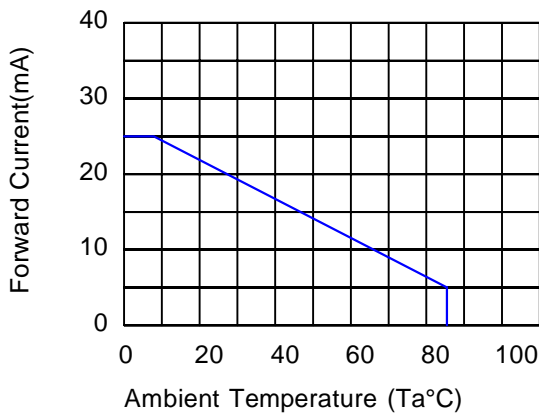

Fig.4 Relative Intensity vs. Temperature

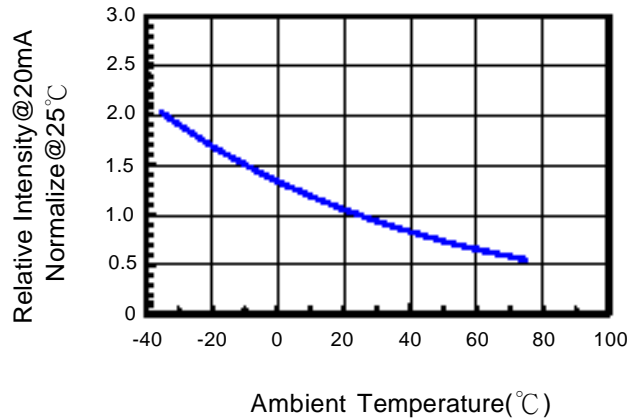

Fig.5 Relative Intensity vs. Wavelength

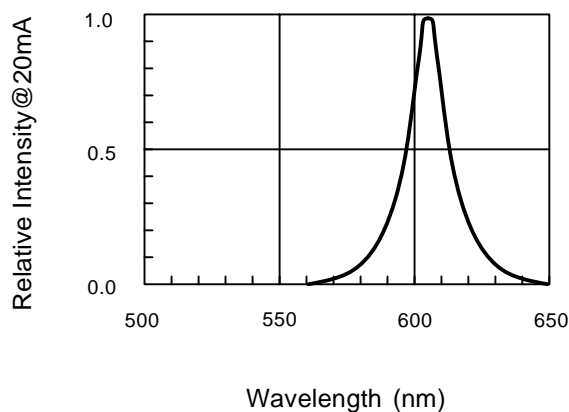
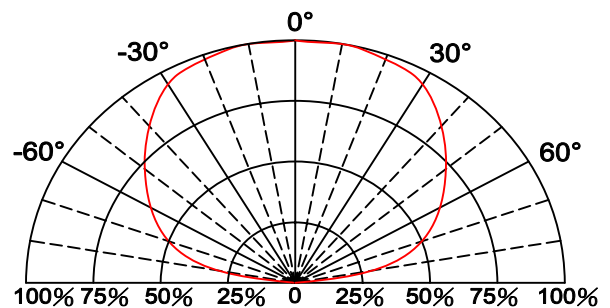

Fig.6 Directive Radiation



## Typical Electro-Optical Characteristics Curve

WK CHIP

Fig.1 Forward current vs. Forward Voltage

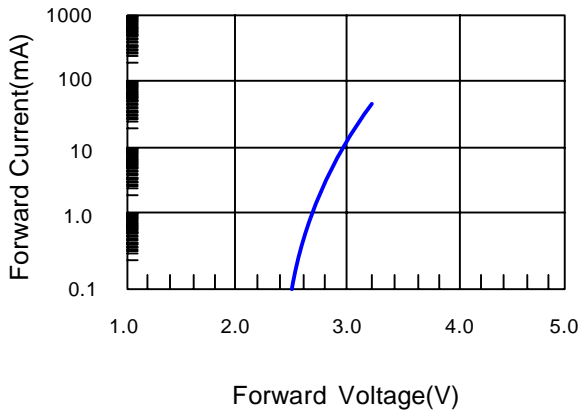

Fig.2 Relative Intensity vs. Forward Current

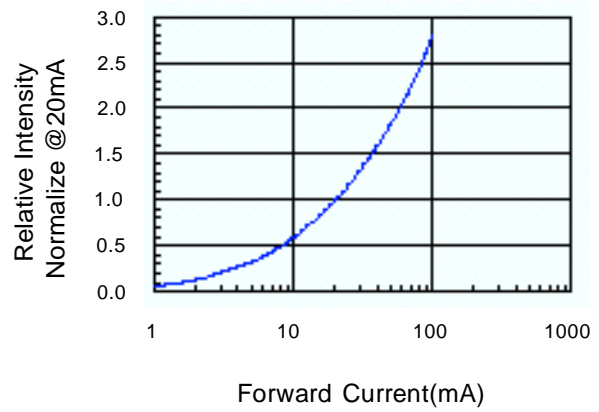

Fig.3 Forward Current vs. Temperature

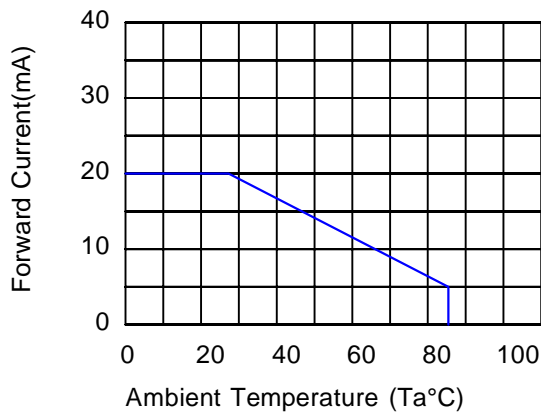

Fig.4 Relative Intensity vs. Temperature

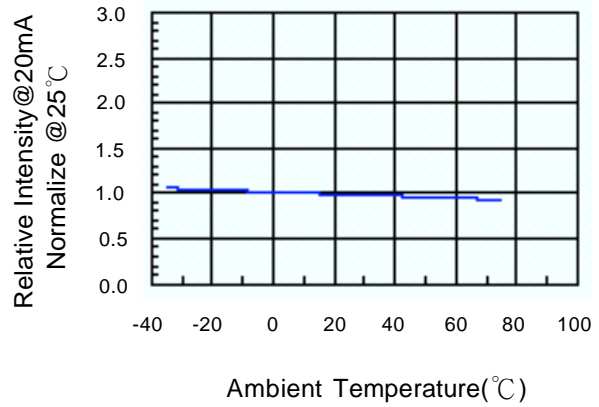

Fig.5 Luminous Spectrum (Ta=25°C)

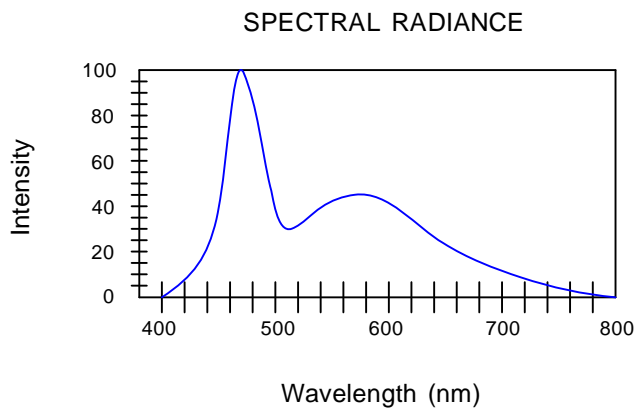
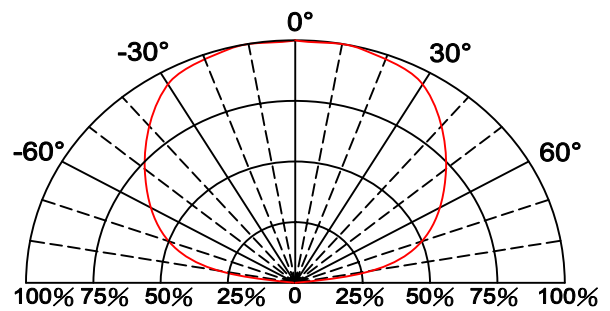
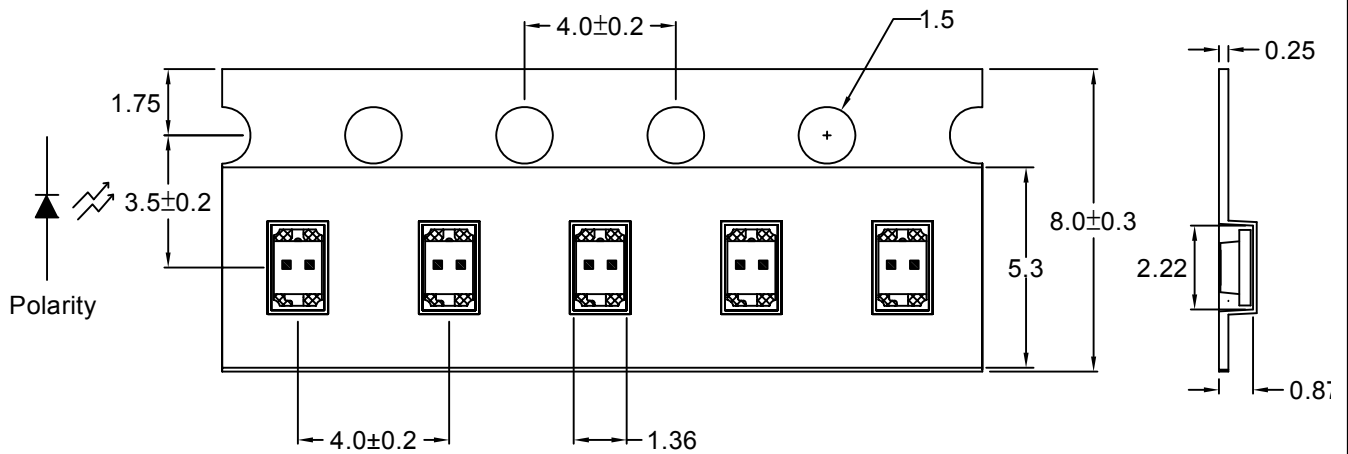

Fig.6 Directive Radiation





## Carrier Type Dimensions



Note : The tolerances unless mentioned is  $\pm 0.1$ mm, Angle  $\pm 0.5$ . Unit=mm.

### • Packing Specifications

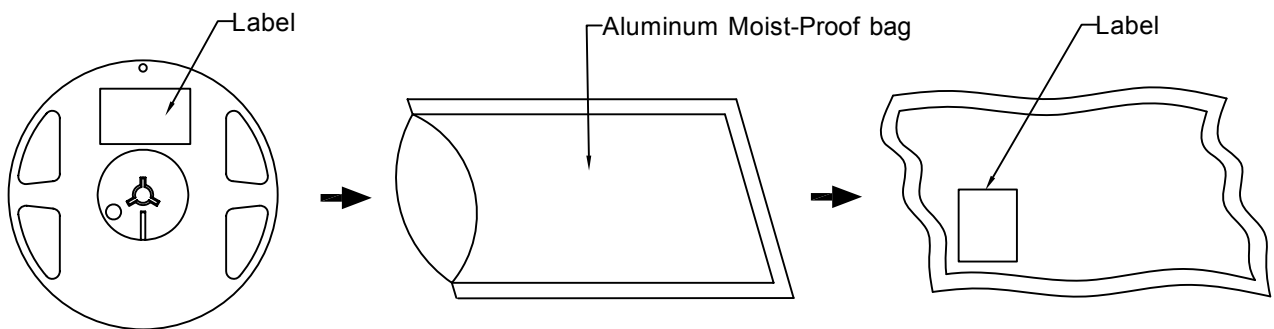

Part No.	Description	Quantity/Reel
LG-170HRF/WK-DT-A01	8.0mm tape,7"reel	4000 devices

## Label Explanation

	LIGITEK ELECTRONICS CO., LTD.	
PART :	LG-170HRF/WK-DT-A01	
LOT :	GS11720168	
QTY(PCS):	4000	
BIN/HUE :	P/30 - T/C3	
		VF: 1.5-2.4
		VF: 2.8-3.6

BIN : Luminous Intensity

HUE : Dominant Wavelength

VF: Chip 1 Forward Voltage

VF : Chip 2 Forward Voltage

## Reel Dimensions

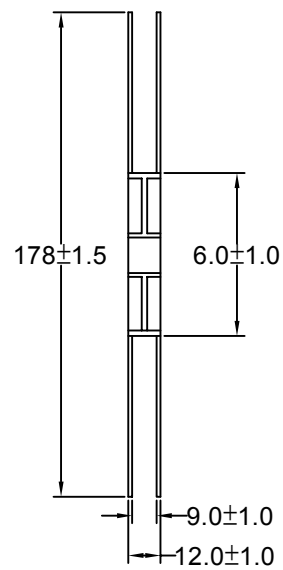
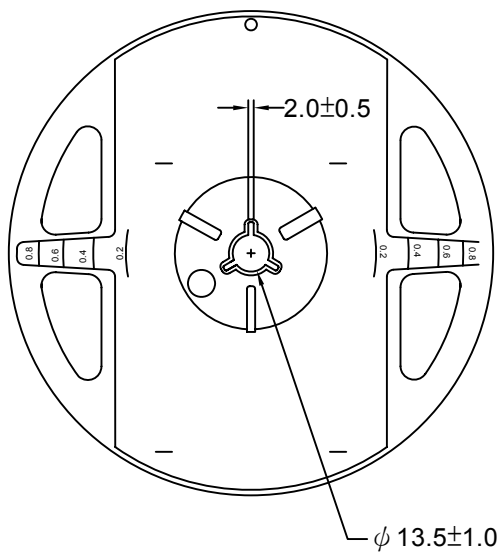

## Box Explanation

1. 5 BAG / INNER BOX
2. INNER BOX SIZE : L X W X H 23cm X 8.5cm x 26cm

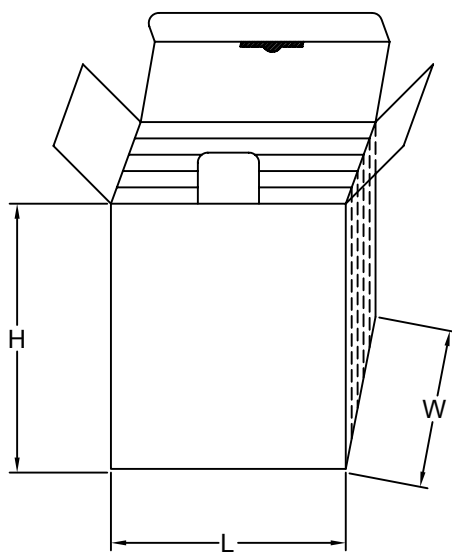

3. 10 INNER BOXES / CARTON
4. CARTON SIZE : L X W X H 58cm X 34cm x 35cm

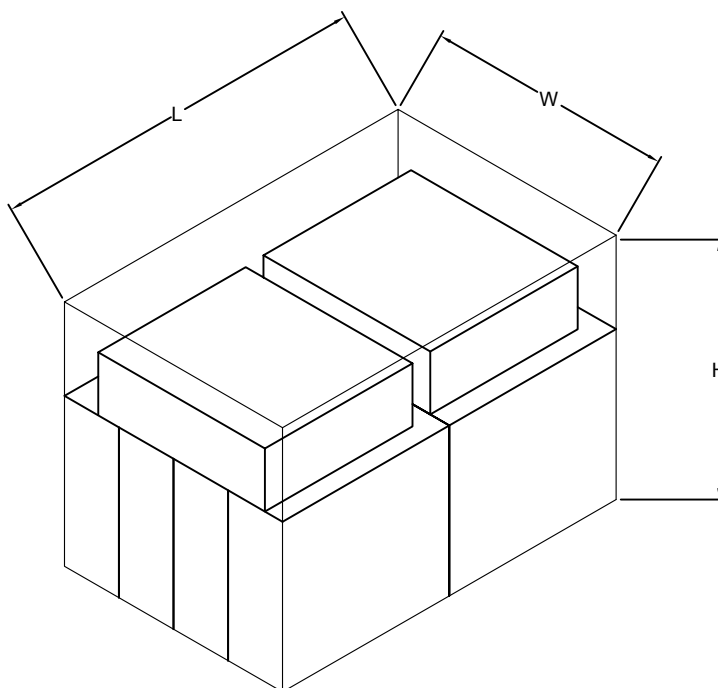

**Recommended Soldering Conditions****1. Hand Solder**

Basic spec is  $\leq 280^{\circ}\text{C}$  3 sec one time only.

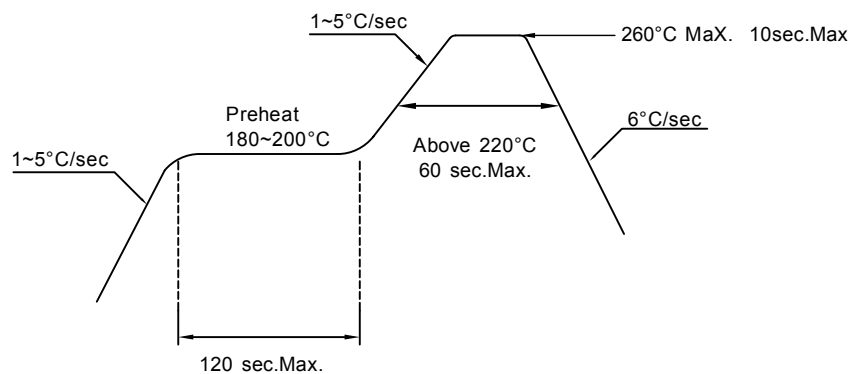
**2. PB-Free Reflow Solder****Note:**

- 1.Reflow soldering should not be done more than two times.
- 2.When soldering,do not put stress on the LEDs during heating.
- 3.After soldering,do not warp the circuit board.

**Precautions For Use:****Storage time:**

1. Calculated shelf life before opening is 18 months at  $< 30^{\circ}\text{C}$  and  $< 90\%$  relative humidity (RH)
2. After bag is opened, devices which will be subjected to reflow soldering or other high temperature processes must be
  - a) Assembled within one years in an environment of  $\leq 30^{\circ}\text{C} / 60\%$  RH, or
  - b) Stored at ambient of  $10\%$  RH or less
3. Devices are required baking before assembly if:
  - a) Humidity Indicator Card reads  $>10\%$  (for level 2a -5a) or  $>60\%$  (for level 2) at ambient temperature  $23\pm 5^{\circ}\text{C}$
  - b) 2.a) or 2.b) doesn't meet
4. If baking is required, devices should be baked for  $>72$  hours at  $60\pm 5^{\circ}\text{C} / 5\%$  RH. Performing baking only once, and using the baked devices within 72 hours..

**Drive Method:**

LED is a current operated device, and therefore, requires some kind of current limiting incorporated into the driver circuit. This current limiting typically takes the form of a current limiting resistor placed in series with the LED.

Consider worst case voltage variations than could occur across the current limiting resistor. The forward current should not be allowed to change by more than 40% of its desired value.

Circuit model A

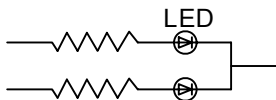

Circuit model B

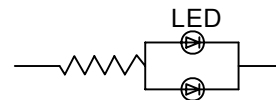

(A) Recommended circuit.

(B) The difference of brightness between LED could be found due to the VF-IF characteristics of LED.

**Cleaning:**

Use alcohol-based cleaning solvents such as isopropyl alcohol to clean the LED.

**ESD(Electrostatic Discharge):**

Static Electricity or power surge will damage the LED. Use of a conductive wrist band or anti-electrostatic glove is recommended when handling these LED. All devices, equipment and machinery must be properly grounded.

Reliability Test:

Classification	Test Item	Test Condition	Sample Size
Endurance Test	Operating Life Test	1.Ta=25°C 2.If=20mA 3.t=1000 hrs (-24hrs,+72hrs)	22
	High Temperature Storage Test	1.Ta=100°C±5°C 2.t=1000 hrs (-24hrs,+72hrs)	22
	Low Temperature Storage Test	1.Ta=-40°C±5°C 2.t=1000 hrs (-24hrs,+72hrs)	22
	High Temperature High Humidity Storage Test	1.Ta=85°C 2.RH=85% 3.t=1000hrs(-24hrs,+72hrs)	22
Environmental Test	Thermal Shock Test	1.Ta=100°C±5°C ~ -40°C±5°C 20min/ 10sec / 20min 2.total 100 cycles	22
	Temperature Cycling	1.100°C±5°C ~ -40°C±5°C 30mins / 5mins / 30mins 2.100 Cyeles	22
	IR Reflow	1.T=260°C Max. 10sec.Max. 2. 6 Min	22