



LIGITEK ELECTRONICS CO.,LTD.
Property of Ligitek Only

SURFACE MOUNT LED TAPE AND REEL



Lead-Free Parts

LG-CU3535HIRR-1-T350-LS6

DATA SHEET

DOC. NO : QW0905-LG-CU3535HIRR-1-T350-LS6

REV. : A

DATE : 11 - May. - 2016



Features:

- 1.Top view LED.
2. Small package with high efficiency
- 3.Soldering methods: IR reflows soldering.
- 4.RoHS compliant
- 5.Pb Free

Applications:

- 1.CCD Camera.
2. infrared applied system

Device Selection Guide:

PART NO	MATERIAL	COLOR	
		Emitted	Lens
LG-CU3535HIRR-1-T350-LS6	AlGaInP	Infrared	Water Clear



Product Nomenclature

LG - CU 3535 HIRR - 1 - T350 - LS6

A B C D E F G

A	B	C	D
Title	Substrate	Dimension(LXW)	Color
LG: Ligitek	CU: Ceramics	3.5 X 3.5mm	HIRR: Infrared
E	F	G	
Chip Modification	Test Current	Lens	
1: 1 chip in 1	T350: 350mA	LS6 :LENS 60°	

Package Dimensions

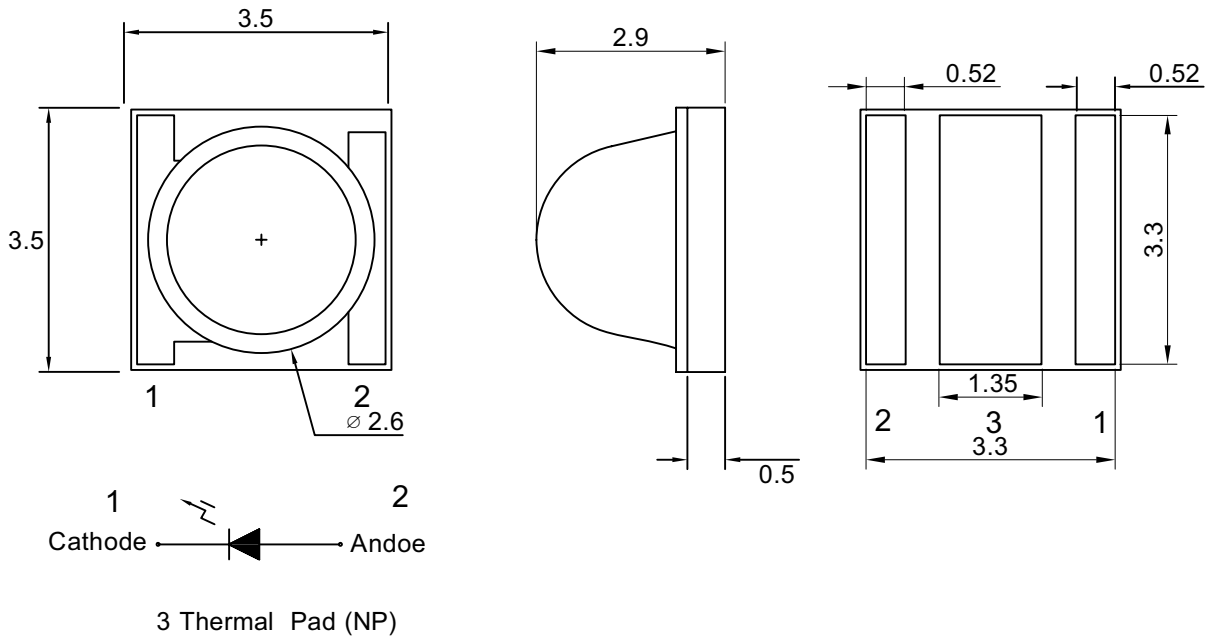

Note : 1.All dimension are in millimeter tolerance is ± 0.2 mm unless otherwise noted.
2.Specifications are subject to change without notice.

Recommended Soldering Pad Dimensions

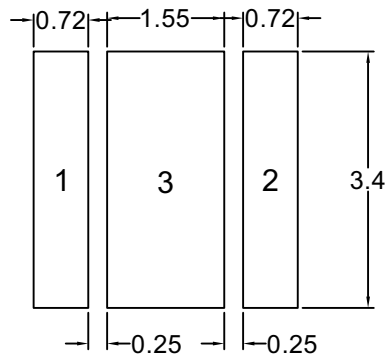

Note : The tolerances unless mentioned is ± 0.1 mm, Unit=mm.

Absolute Maximum Ratings at Ta=25°C

Parameter	Symbol	Ratings	UNIT
Power Dissipation	Pd	1.45	W
DC Forward Current	IF	500	mA
Reverse Current(VR=5V)	Ir	10	μA
Peak pulse current Duty1/10@10KHz	I _{FP}	1000	mA
ESD Sensitivity	HBM 100pf/1.5 KΩ	2000	V
	MM 200pf/0Ω	150	V
LED junction Temperature	Tj	115	°C
Thermal resistance	Rth _{j-s}	8	°C/W
Operating Temperature	Topr	-40 ~ +85	°C
Storage Temperature	Tstg	-40 ~ +100	°C
Soldering Temperature	Tp	260	°C

Typical Electrical & Optical Characteristics (Ta=25°C)

Parameter	Symbol	Min.	Typ.	Max.	UNIT	CONDITION
Radiant Intensity	Le	170	210	----	mw/sr	IF=350mA
Peak Emission Wavelength	λP	----	850	----	nm	IF=350mA
Spectral Bandwidth at 50% of I _{max}	$\Delta \lambda$	----	40	----	nm	IF=350mA
Forward Voltage	VF	1.4	----	2.9	V	IF=350mA
Viewing Angle	2 θ 1/2	----	60	----	deg	IF=350mA

Note : 1.The forward voltage data did not including $\pm 0.1V$ testing tolerance.
2.The radiant intensity data did not including $\pm 15\%$ testing tolerance.

Radiant Intensity Classification

BIN CODE	Le(mw/sr) at 350mA	
	Min.	Max.
E1	170	210
E2	210	250
E3	250	300

Forward Voltage Classification

BIN CODE	Vf(V) at 350mA	
	Min.	Max.
1	1.4	1.7
2	1.7	2
3	2	2.3
4	2.3	2.6
5	2.6	2.9

Typical Electro-Optical Characteristics Curve

Fig.1 Relative Intensity VS. Forward Current

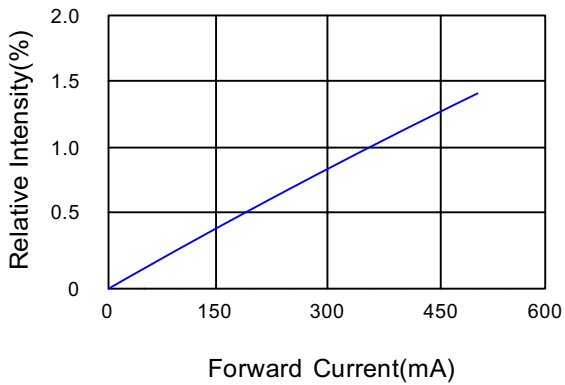

Fig.2 Forward Current VS. Ambient Temperature

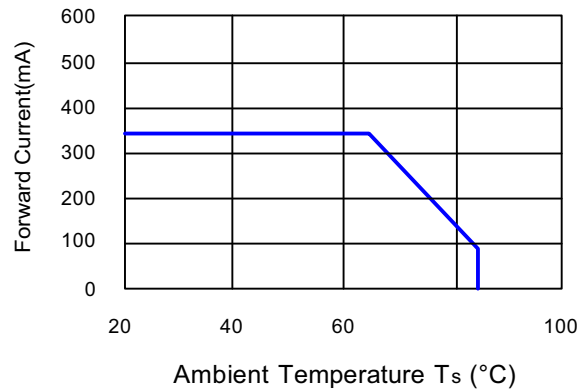

Fig.3 Relative Radiant Power VS. Wavelength

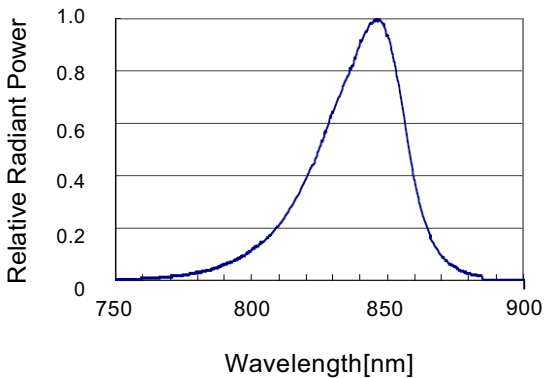

Fig.4 Forward Voltage VS. Forward Current

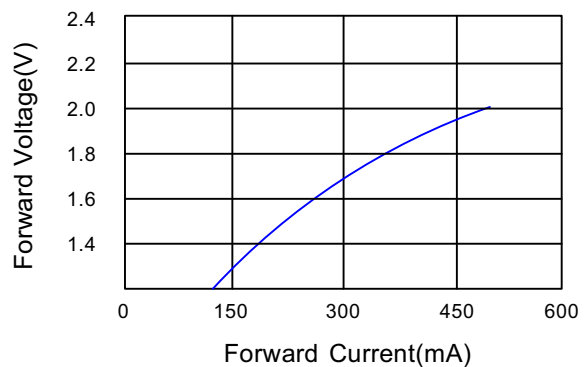
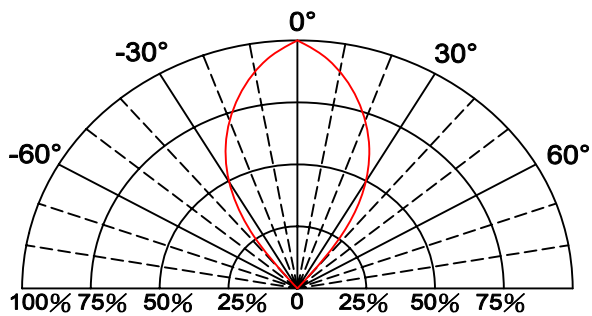
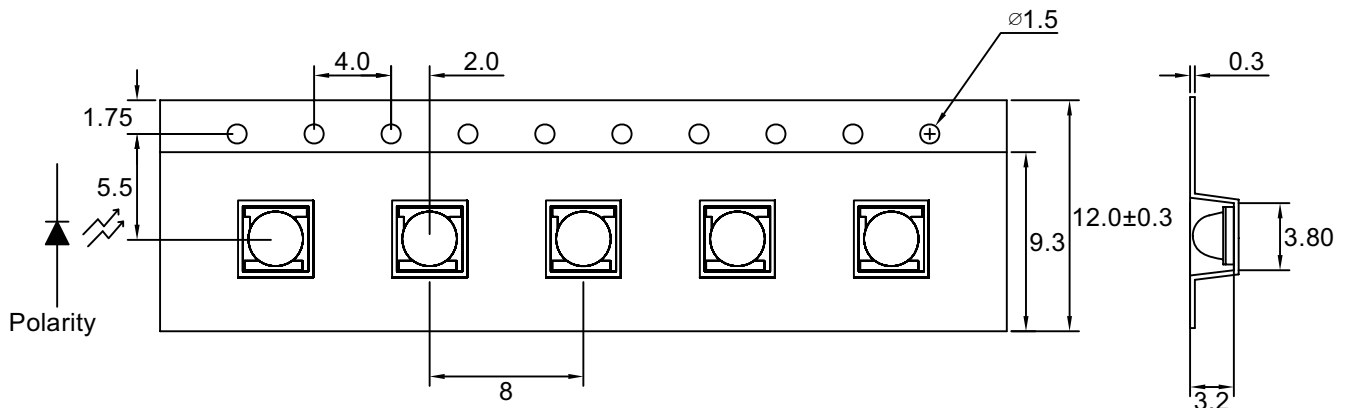

Fig.5 Directive Radiation



Carrier Type Dimensions







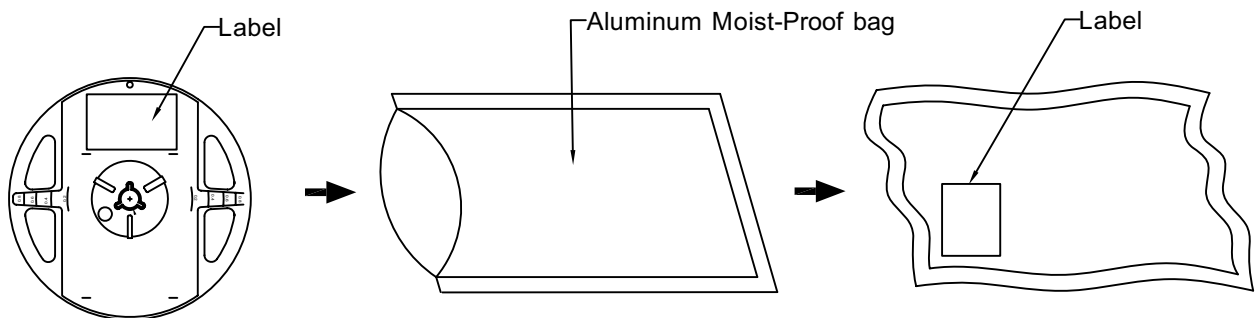

Note : The tolerances unless mentioned is $\pm 0.1\text{mm}$, Angle ± 0.5 . Unit=mm.

• Packing Specifications



Part No.	Description	Quantity/Reel
LG-CU3535HIRR-1-T350-LS6	12.0mm tape,7"reel	500 PCS

Label Explanation

	LIGITEK ELECTRONICS CO., LTD.	
		
	PART :	LG-CU3535HIRR-1-T350-LS6
		
	LOT :	GS1630168
		
QTY(PCS):	500	
		
BIN/HUE :	E1	 VF:1.7-2.0

BIN : Radiant Intensity

VF: Forward Voltage

Reel Dimensions

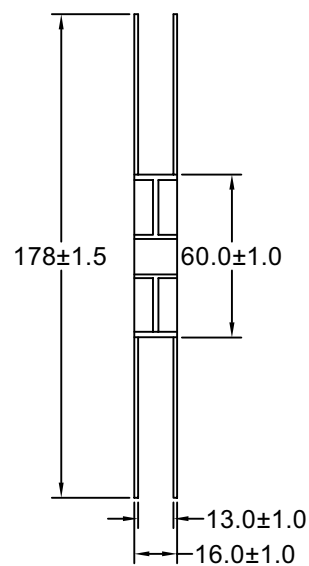
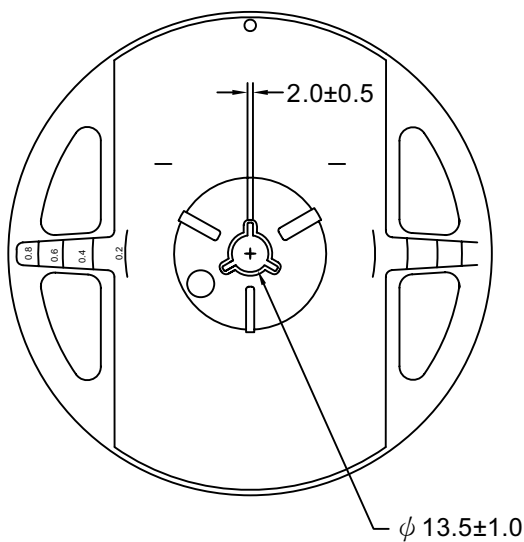

Box Explanation

1. 4 BAG / INNER BOX

2. INNER BOX SIZE : L X W X H 23cm X 8.5cm x 26cm

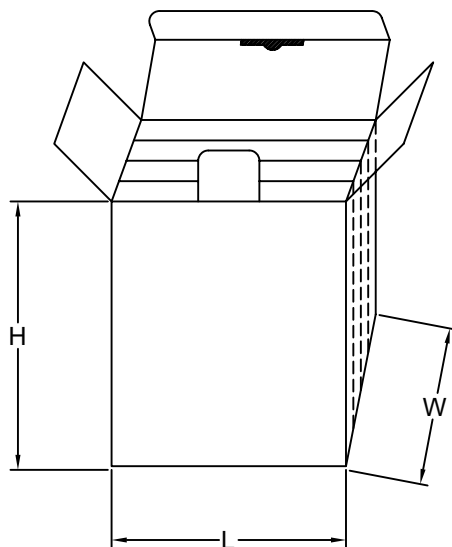

3. 10 INNER BOXES / CARTON

4. CARTON SIZE : L X W X H 58cm X 34cm x 35cm

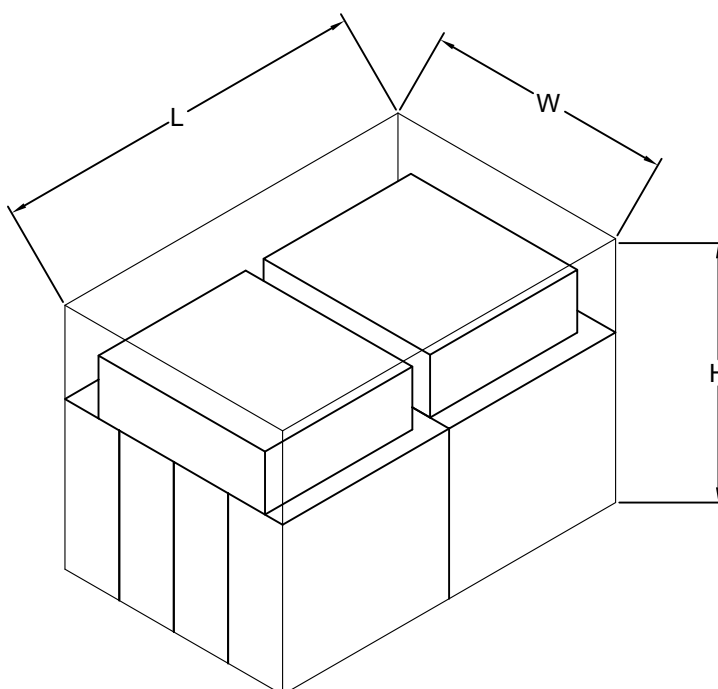

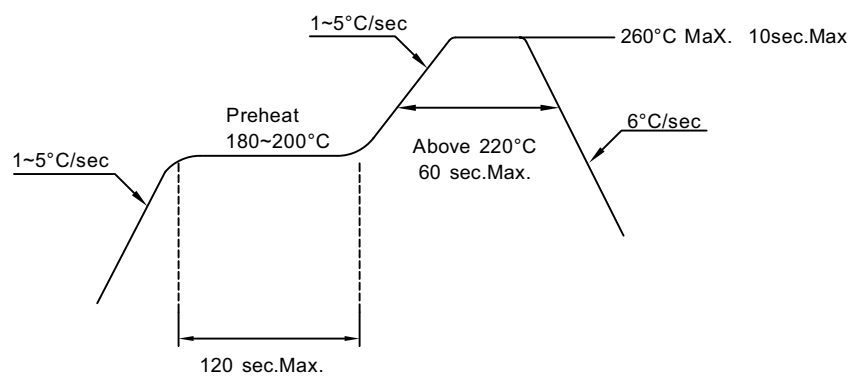
Recommended Soldering Conditions**PB-Free Reflow Solder****Note:**

- 1.Reflow soldering should not be done more than two times.
- 2.When soldering,do not put stress on the LEDs during heating.
- 3.After soldering,do not warp the circuit board.

Precautions For Use:**Storage time:**

1. Calculated shelf life before opening is 12 months at $< 30^{\circ}\text{C}$ and $< 90\%$ relative humidity (RH)
2. After bag is opened, devices which will be subjected to reflow soldering or other high temperature processes must be
 - a) Assembled within 168 hours in an environment of $\leq 30^{\circ}\text{C} / 60\%$ RH, or
 - b) Stored at ambient of 10% RH or less
3. Devices are required baking before assembly if:
 - a) Humidity Indicator Card reads $>10\%$ (for level 2a -5a) or $>60\%$ (for level 2) at ambient temperature $23 \pm 5^{\circ}\text{C}$
 - b) 2.a) or 2.b) doesn't meet
4. If baking is required, devices should be baked for >24 hours at $60 \pm 5^{\circ}\text{C}$. Performing baking only once, and using the baked devices within 72 hours.

Drive Method:

LED is a current operated device, and therefore, requires some kind of current limiting incorporated into the driver circuit. This current limiting typically takes the form of a current limiting resistor placed in series with the LED.

Consider worst case voltage variations than could occur across the current limiting resistor. The forward current should not be allowed to change by more than 40% of its desired value.

Circuit model A

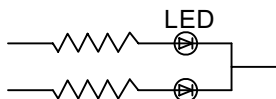

Circuit model B

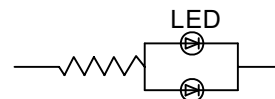

(A) Recommended circuit.

(B) The difference of brightness between LED could be found due to the VF-IF characteristics of LED.

Cleaning:

Use alcohol-based cleaning solvents such as isopropyl alcohol to clean the LED.

ESD(Electrostatic Discharge):

Static Electricity or power surge will damage the LED. Use of a conductive wrist band or anti-electrostatic glove is recommended when handling these LED. All devices, equipment and machinery must be properly grounded.

Reliability Test:

Classification	Test Item	Test Condition	Sample Size
Endurance Test	Operating Life Test	1.Ta=25°C 2.If=350mA 3.t=1000 hrs (-24hrs,+72hrs)	22
	High Temperature Storage Test	1.Ta=100°C±5°C 2.t=1000 hrs (-24hrs,+72hrs)	22
	Low Temperature Storage Test	1.Ta=-40°C±5°C 2.t=1000 hrs (-24hrs,+72hrs)	22
	High Temperature High Humidity Storage Test	1.Ta=85°C 2.RH=85% 3.t=1000hrs(-24hrs,+72hrs)	22
Environmental Test	Thermal Shock Test	1.Ta=100°C±5°C ~ -40°C±5°C 20min/ 10sec / 20min 2.total 100 cycles	22
	Temperature Cycling	1.100°C±5°C ~ -40°C±5°C 30mins / 5mins / 30mins 2.100 Cyeles	22
	IR Reflow	1.T=260°C Max. 10sec.Max. 2. 6 Min	22

Please follow the guideline to grab LEDs

- don't touch lens with the fingers
- use tweezers to grab LED
- don't apply more than 4N of lens(400G) directly onto the lens
- don't touch lens with the tweezers

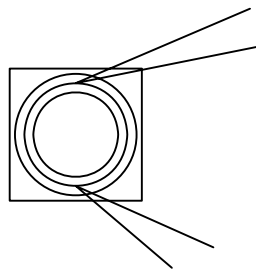

Wrong(x)

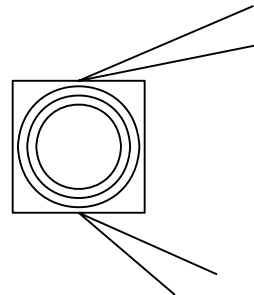

Correct(o)

Lens cleaning

in the case where a minimal level of dirt and dust particles can not be guaranteed, a suitable cleaning solution can be applied to the lens surface

- try a gentle swabbing using a lint-free swab
- if needed, the use of lint-free swab and isopropyl alcohol used gently removes dirt from the lens
- don't use other solvents as they may directly react with the led assembly.
- don't use ultrasonic cleaning that the led will be damaged