



LIGITEK ELECTRONICS CO.,LTD.
Property of Ligitek Only

SURFACE MOUNT LED TAPE AND REEL



Lead-Free Parts

LWK9553-WW-A01

DATA SHEET

DOC. NO : QW0905-LWK9553-WW-A01

REV. : A

DATE : 06 - Oct. - 2014



Features:

1. Top view white LED.
2. white SMT package.
3. Leadframe package with individual 2 pin.
4. Wide viewing angle.
5. Soldering methods: IR reflow soldering.
6. Feature of the device: more light due to higher optical efficiency; extremely wide viewing angle; ideal for backlighting and coupling in light guide.

Descriptions:

The LWK9553 SMD has wide viewing angle, low power consumption and white LEDs are devices which are materialized by combining blue LEDs and special phosphors. This feature makes the LED ideal for light guide application.

Applications:

1. LCD back light.
2. Mobile phones.
3. Indicators.
4. Switch lights.

Device Selection Guide:

| PART NO | MATERIAL | COLOR | |
|----------------|----------|---------|-----------------|
| | | Emitted | Lens |
| LWK9553-WW-A01 | InGaN | White | Yellow Diffused |

Package Dimensions

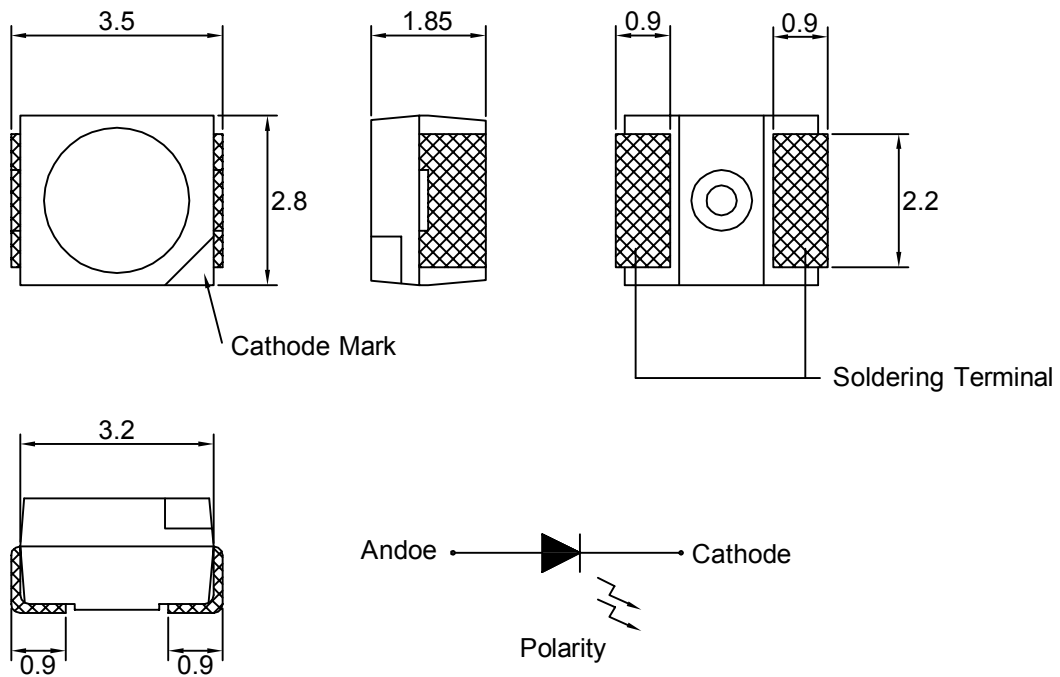

Note : 1.All dimension are in millimeter tolerance is $\pm 0.2\text{mm}$ unless otherwise noted.
2.Specifications are subject to change without notice.

Recommended Soldering Pad Dimensions

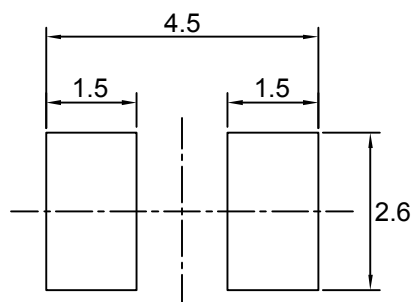

Note : The tolerances unless mentioned is $\pm 0.1\text{mm}$, Unit=mm.

Absolute Maximum Ratings at Ta=25 °C

| Parameter | Symbol | Ratings | UNIT |
|---|--------|--------------|------|
| Forward Current | IF | 30 | mA |
| Peak Forward Current Duty 1/10@10KHz | IFP | 100 | mA |
| Power Dissipation | PD | 108 | mW |
| Reverse Current @5V | Ir | 50 | μA |
| Electrostatic Discharge | ESD | 500 | V |
| Operating Temperature | Topr | - 20 ~ + 80 | °C |
| Storage Temperature | Tstg | - 30 ~ + 100 | °C |

Typical Electrical & Optical Characteristics (Ta=25 °C)

| Items | Symbol | Min. | Typ. | Max. | UNIT | CONDITION |
|--------------------------|----------------|-------|------|-------|------|-----------|
| Luminous Intensity | Iv | 2000 | 2300 | ---- | mcd | IF=20mA |
| Chromaticity Coordinates | X | 0.49 | ---- | 0.541 | ---- | IF=20mA |
| | Y | 0.411 | ---- | 0.453 | ---- | IF=20mA |
| Forward Voltage | V _F | 2.8 | ---- | 3.6 | V | IF=20mA |
| Viewing Angle | 2θ 1/2 | ---- | 120 | ---- | deg | IF=20mA |

Note : 1.The forward voltage data did not including ±0.1V testing tolerance.
2.The luminous intensity data did not including ±15% testing tolerance.
3.The color coordinates measurement allowance is ±0.01 testing tolerance.

Luminous Intensity Classification

| BIN CODE | Iv(mvd) at20mA | |
|----------|----------------|------|
| | Min. | Max. |
| X11X12 | 2000 | 2100 |
| X13X14 | 2100 | 2200 |
| X15X16 | 2200 | 2300 |
| X17X18 | 2300 | 2400 |
| X19X20 | 2400 | 2500 |
| X21X22 | 2500 | 2600 |

Forward Voltage Classification

| BIN CODE | Vf(v) at20mA | |
|----------|--------------|------|
| | Min. | Max. |
| 1 | 2.8 | 2.9 |
| 2 | 2.9 | 3.0 |
| 3 | 3.0 | 3.1 |
| 4 | 3.1 | 3.2 |
| 5 | 3.2 | 3.3 |
| 6 | 3.3 | 3.4 |
| 7 | 3.4 | 3.5 |
| 8 | 3.5 | 3.6 |

Chromaticity Coordinates Specifications For Bin Grading

| Color Coordiante at 20mA | | | | | | | | | |
|--------------------------|----------|--------|--------|--------|--------|--------|--------|--------|--------|
| CCT(K) | BIN CODE | 1 | | 2 | | 3 | | 4 | |
| | | X | Y | X | Y | X | Y | X | Y |
| 2070~2220 | HN | 0.5150 | 0.4320 | 0.5310 | 0.4360 | 0.5410 | 0.4530 | 0.5250 | 0.4490 |
| | HO | 0.5060 | 0.4150 | 0.5220 | 0.4190 | 0.5310 | 0.4360 | 0.5150 | 0.4320 |
| 2220~2370 | JN | 0.4990 | 0.4280 | 0.5150 | 0.4320 | 0.5250 | 0.4490 | 0.5090 | 0.4450 |
| | JO | 0.4900 | 0.4110 | 0.5060 | 0.4150 | 0.5150 | 0.4320 | 0.4990 | 0.4280 |

CIE Chromaticity Diagram

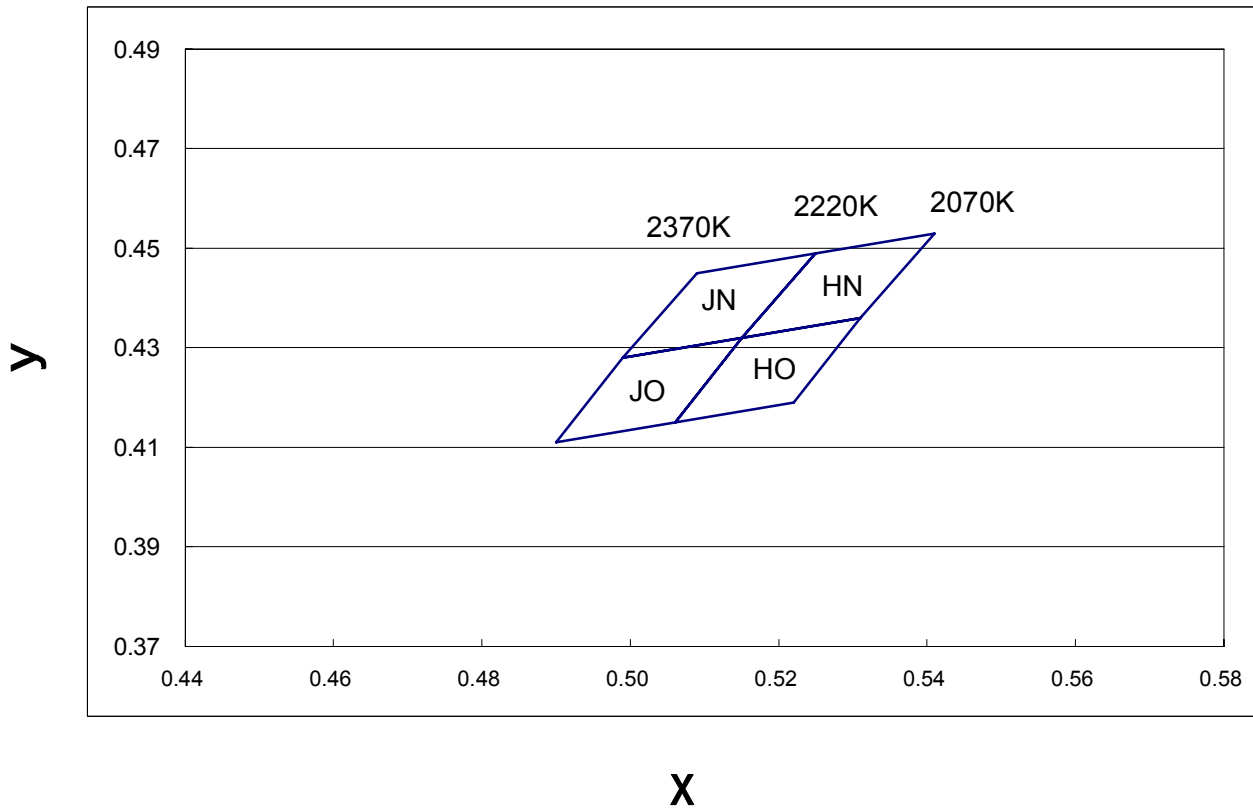

Typical Electro-Optical Characteristics Curve

WK CHIP

Fig.1 Forward current vs. Forward Voltage

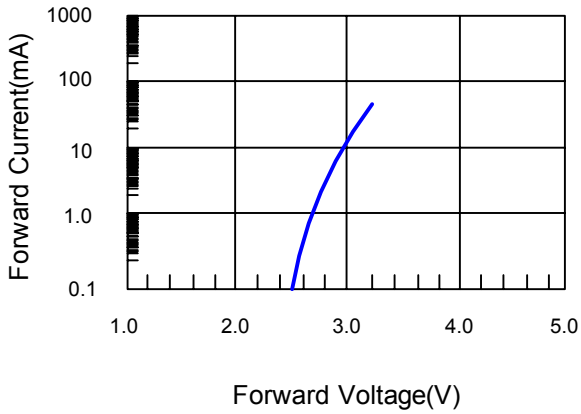

Fig.2 Relative Intensity vs. Forward Current

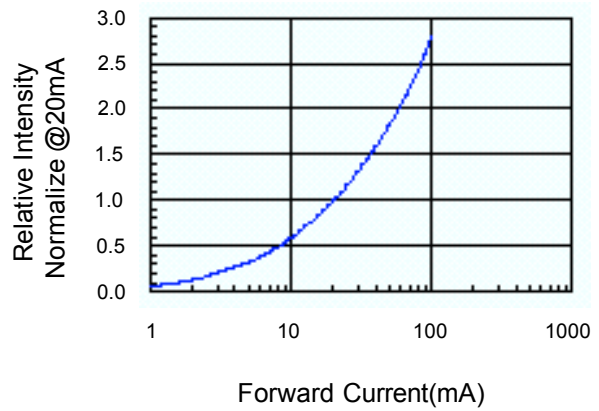

Fig.3 Forward Voltage vs. Temperature

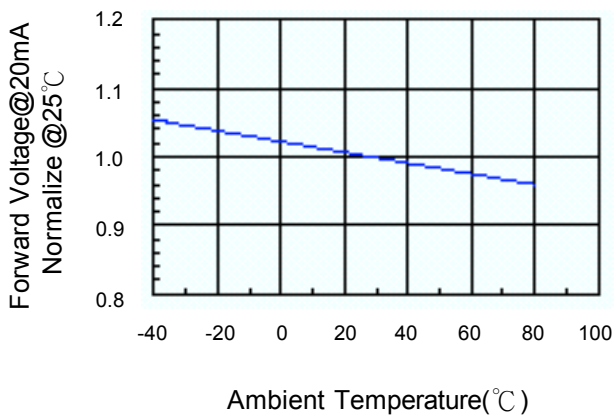

Fig.4 Relative Intensity vs. Temperature

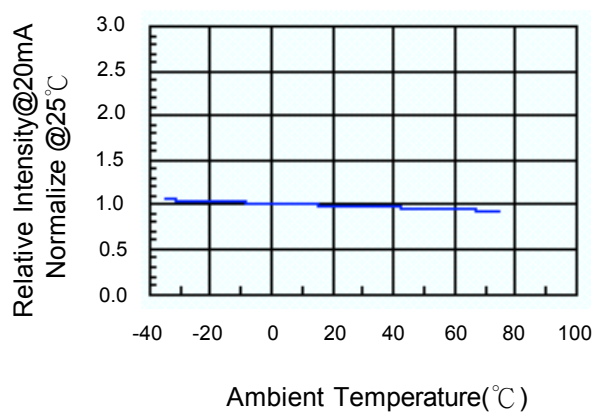

Fig.5 Luminous Spectrum (Ta=25°C)

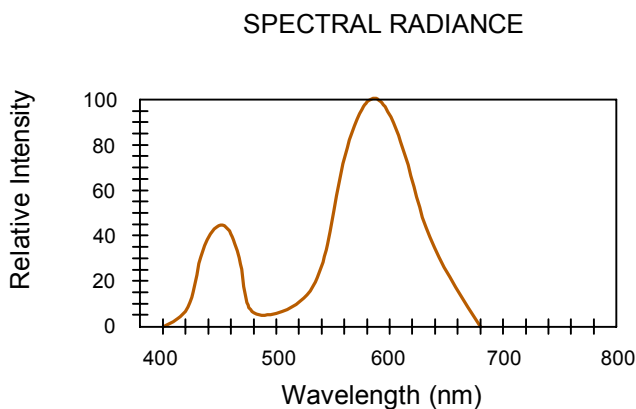
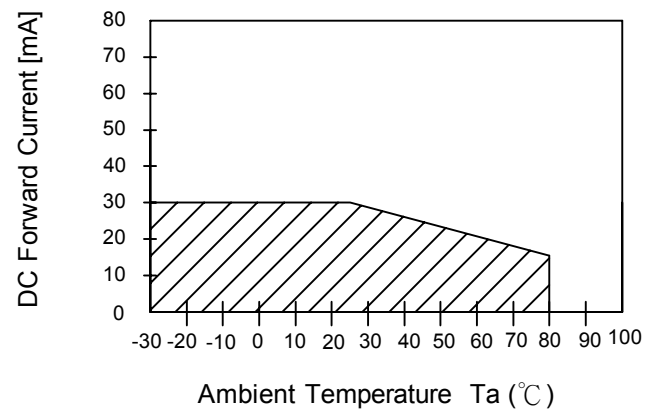
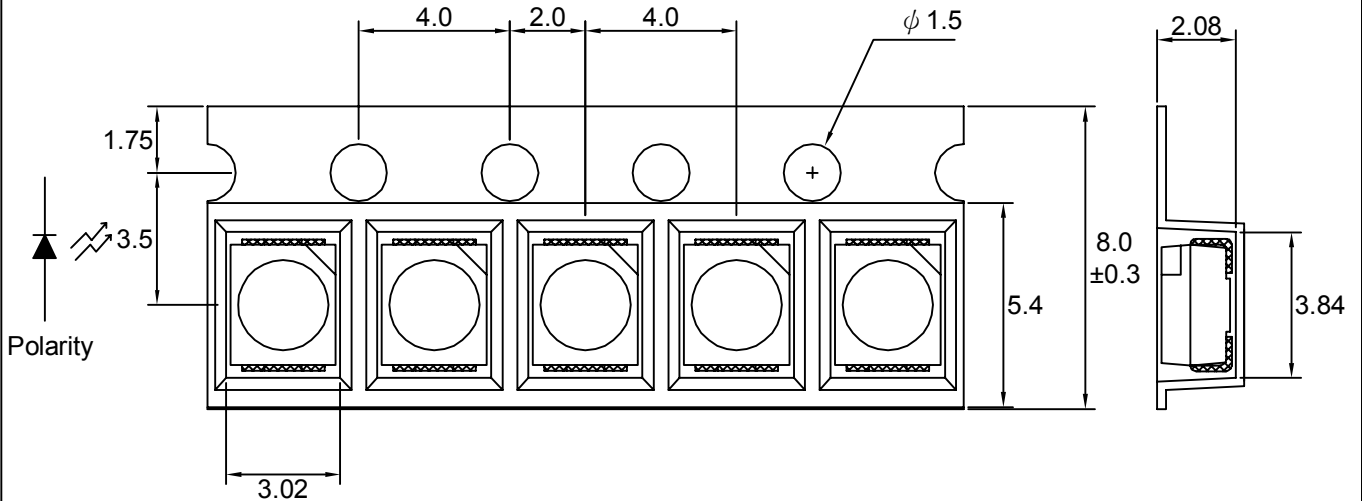

Fig.6 Forward Current vs. Temperature



Carrier Type Dimensions



Note : The tolerances unless mentioned is $\pm 0.1\text{mm}$, Angle ± 0.5 . Unit=mm.

• Packing Specifications

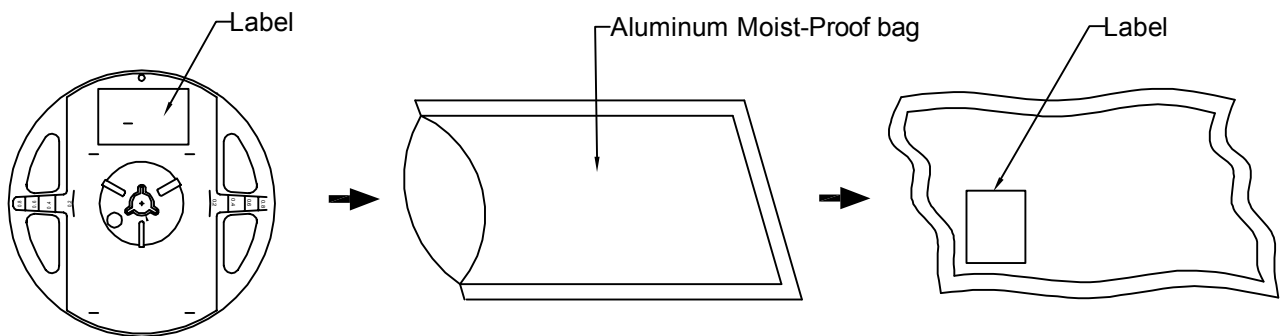

| Part No. | Description | Quantity/Reel |
|----------------|-------------------|---------------|
| LWK9553-WW-A01 | 8.0mm tape,7"reel | 2000 PCS |

Label Explanation

| | |
|---|----------------|
|  LIGITEK ELECTRONICS CO., LTD. | |
| PART : | LWK9553-WW-A01 |
| LOT : | GS114A0168 |
| QTY(PCS): | 2000 |
| BIN/HUE : | X17X18/HN |
| | VF:3.1-3.2 |

BIN : Luminous Intensity

HUE : Chromaticity Coordinates
(CIE_x , CIE_y)

3.1 - 3.2 : Forward Voltage

Reel Dimensions

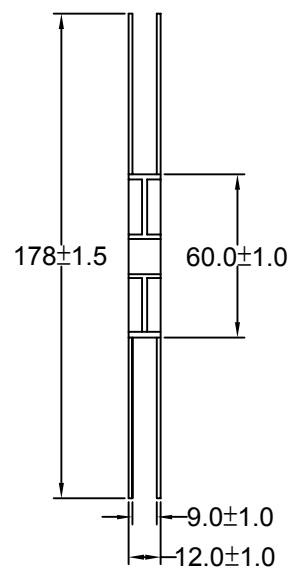
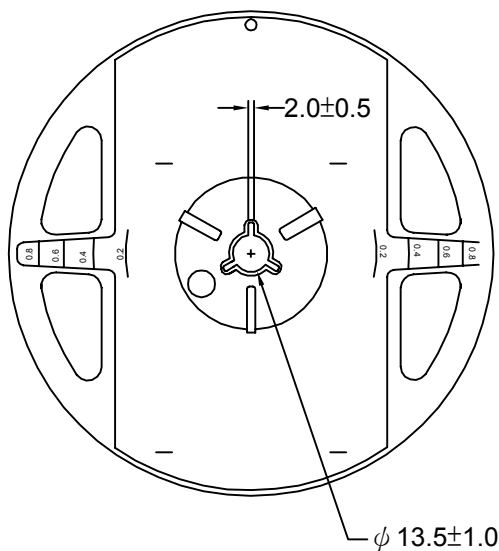

Box Explanation

1. 5 BAG / INNER BOX

2. INNER BOX SIZE : L X W X H 23cm X 8.5cm x 26cm

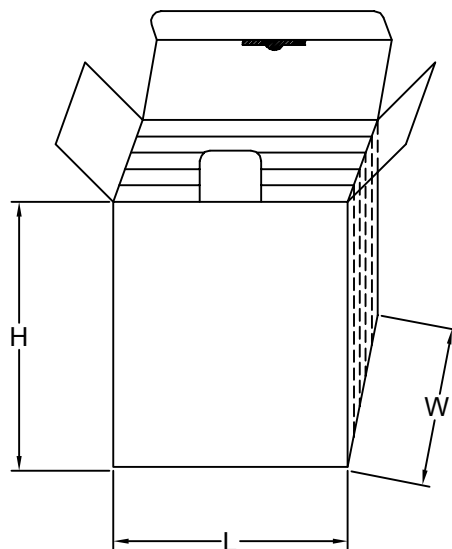

3. 10 INNER BOXES / CARTON

4. CARTON SIZE : L X W X H 58cm X 34cm x 35cm

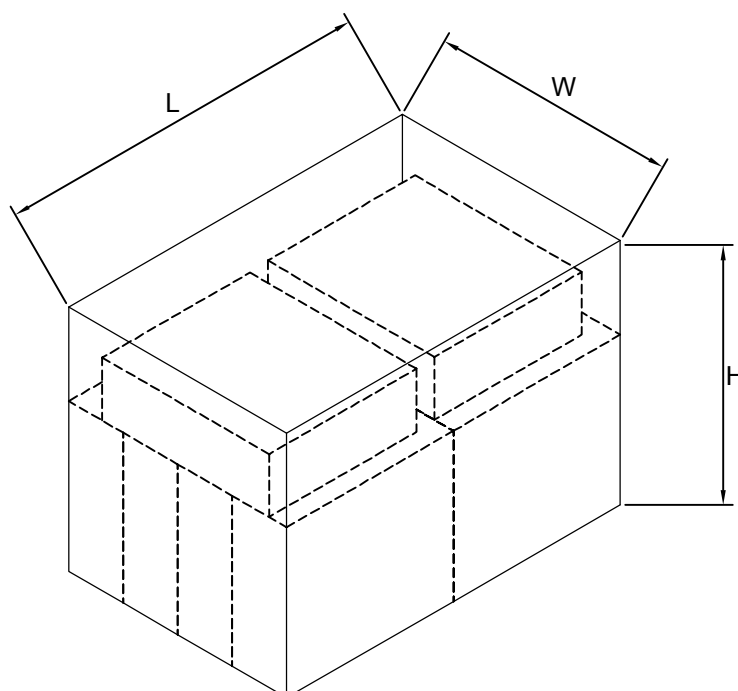

Recommended Soldering Conditions**1. Hand Solder**

Basic spec is $\leq 320^{\circ}\text{C}$ 3 sec one time only.

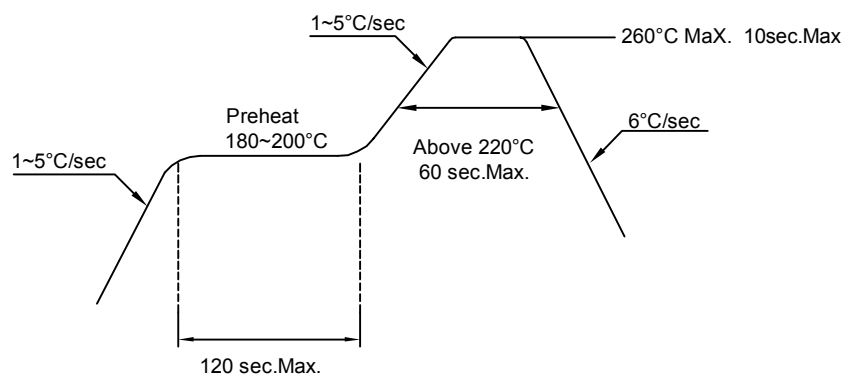
2. PB-Free Reflow Solder**Note:**

- 1.Reflow soldering should not be done more than two times.
- 2.When soldering,do not put stress on the LEDs during heating.
- 3.After soldering,do not warp the circuit board.

Precautions For Use:**Storage time:**

- 1.The operation of Temperatures and RH are : $5^{\circ}\text{C}\sim 35^{\circ}\text{C}$,RH60%.
- 2.Once the package is opened, the products should be used within a week.
Otherwise, they should be kept in a damp proof box with descanting agent.
Considering the tape life, we suggest our customers to use our products within a year(from production date).
- 3.If opened more than one week in an atmosphere $5^{\circ}\text{C} \sim 35^{\circ}\text{C}$,RH60%, they should be treated at $60^{\circ}\text{C}\pm 5^{\circ}\text{C}$ fo r 15hrs.

Drive Method:

LED is a current operated device, and therefore, requirer some kind of current limiting incorporated into the driver circuit. This current limiting typically takes the form of a current limiting resistor placed in series with the LED.

Consider worst case voltage variations than could occur across the current limiting resistor. The forwr d current should not be allowed to change by more than 40% of its desired value.

Circuit model A

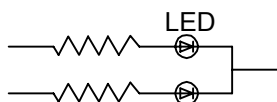

Circuit model B

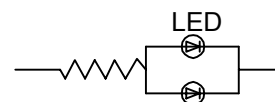

(A) Recommended circuit.

(B) The difference of brightness between LED could be found due to the VF-IF characteristics of LED.

Cleaning:

Use alcohol-based cleaning solvents such as isopropyl alcohol to clean the LED.

ESD(Electrostatic Discharge):

Static Electricity or power surge will damage the LED. Use of a conductive wrist band or anti-electrosatic glove is recommended when handing these LED. All devices, equipment and machinery must be properly grounded.

Reliability Test:

(1)Test items and results

| Classification | Test Item | Test Condition | Sample Size |
|--------------------|---|--|-------------|
| Endurance Test | Operating Life Test | 1.Ta=Under Room Temperature As Per Data Sheet Maximum Rating. 2.If=20mA 3.t=1000 hrs | 22 |
| | High Temperature Storage Test | 1.Ta=105 °C±5°C 2.t=500 hrs | 22 |
| | Low Temperature Storage Test | 1.Ta=-40 °C±5°C 2.t=1000 hrs | 22 |
| | High Temperature High Humidity Storage Test | 1.IR-Reflow In-Board, 2 Times 2.Ta=85°C±5°C 3.RH=90 %~95% 4.t=500hrs±2hrs | 22 |
| Environmental Test | Thermal Shock Test | 1.IR-Reflow In-Board,2 times 2.Ta=105 °C±5°C & -40°C±5°C (30min) (30min) 3.total 100 cycles | 22 |
| | Reflow Soldering Test | 1.T.Sol=260 °C±5°C 2.Dwell Time= 10 Max . | 22 |
| | Temperature Cycling | 1.105°C ~ 25°C ~ -40°C 30mins 15mins 30mins 2.100 Cyeles | 22 |

(2)Criteria for judging the damage

| Item | Symbol | Test Conditions | Criteria for Judgement | |
|--------------------|--------|-----------------|------------------------|------------|
| | | | Min. | Max. |
| Forward Voltage | Vf | If=20mA | - | U.S.L x1.2 |
| Reverse Current | Ir | Vr=5V | - | U.S.L x2.0 |
| Luminous Intensity | Iv | If=20mA | L.S.L x 0.5 | - |

Note:

1.U.S.L.:Upper Standard Level.

2.L.S.L.:Lower Standard Level.