



LIGITEK ELECTRONICS CO.,LTD.  
Property of Ligitek Only

SURFACE MOUNT LED TAPE AND REEL



Lead-Free Parts

LWK9S53-HC-T60-C-D702

## DATA SHEET

DOC. NO : QW0905-LWK9S53-HC-T60-C-D702

REV. : A

DATE : 06 - Dec. - 2017



### Features:

1. Top view white LED.
2. white SMT package.
3. Leadframe package with individual 2 pin.
4. Wide viewing angle.
5. Soldering methods: IR reflow soldering.
6. Feature of the device: more light due to higher optical efficiency; extremely wide viewing angle; ideal for backlighting and coupling in light guide.

### Descriptions:

The LWK9S53 SMD has wide viewing angle, low power consumption and white LEDs are devices which are materialized by combining blue LEDs and special phosphors. This feature makes the LED ideal for light guide application.

### Applications:

1. LCD back light.
2. Mobile phones.
3. Indicators.
4. Switch lights.

### Device Selection Guide:

PART NO	MATERIAL	COLOR	
		Emitted	Lens
LWK9S53-HC-T60-C-D702	InGaN	White	Yellow Diffused

**Package Dimensions**

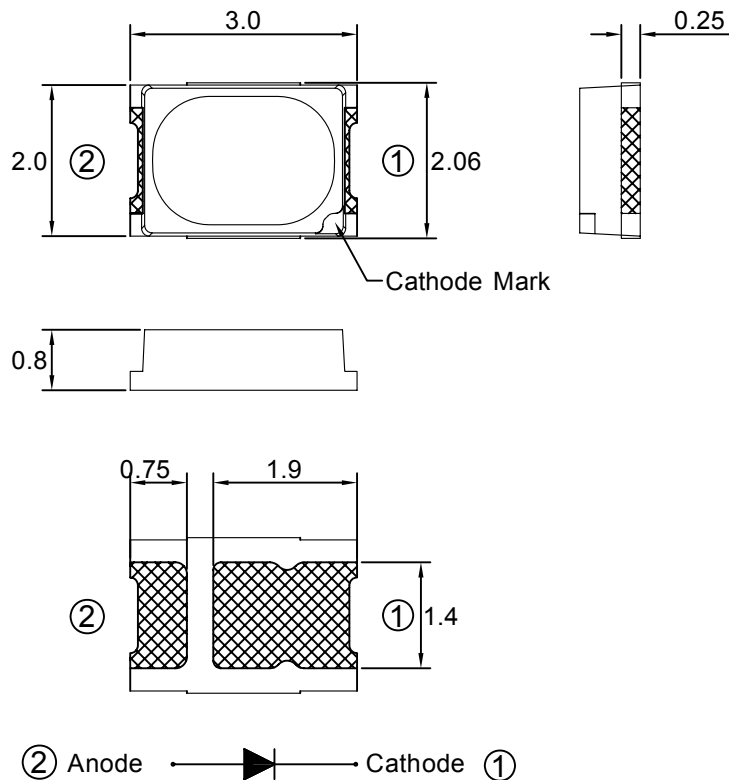

Note : 1.All dimension are in millimeter tolerance is  $\pm 0.2\text{mm}$  unless otherwise noted.  
 2.Specifications are subject to change without notice.

**Recommended Soldering Pad Dimensions**

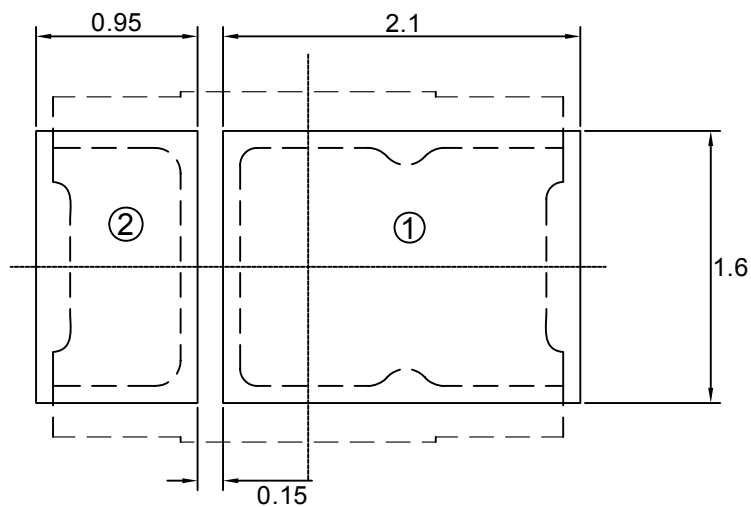

Note : The tolerances unless mentioned is  $\pm 0.1\text{mm}$ , Unit=mm.

### Absolute Maximum Ratings at Ta=25°C

Parameter	Symbol	Ratings	UNIT
Forward Current	IF	60	mA
Peak Forward Current Duty 1/10@10KHz	IFP	100	mA
Power Dissipation	PD	216	mW
Reverse Current @5V	Ir	50	μA
Electrostatic Discharge	ESD	500	V
Operating Temperature	Topr	- 40 ~ + 85	°C
Storage Temperature	Tstg	- 40 ~ + 100	°C

### Typical Electrical & Optical Characteristics (Ta=25°C)

Items	Symbol	Min.	Typ.	Max.	UNIT	CONDITION
Luminous Intensity	Iv	18	22	----	lm	IF=60mA
Chromaticity Coordinates	X	0.3207	----	0.3376	----	IF=60mA
	Y	0.3243	----	0.3963	----	IF=60mA
Forward Voltage	V <sub>F</sub>	2.8	----	3.6	V	IF=60mA
Color Rendering Index	CRI	70	----	---	----	IF=60mA
Viewing Angle	2θ 1/2	----	120	----	deg	IF=60mA

- Note : 1.The forward voltage data did not including ±0.1V testing tolerance.  
 2.The luminous intensity data did not including ±15% testing tolerance.  
 3.The color coordinates measurement allowance is ±0.01 testing tolerance  
 4.The CRI measurement allowance is ±2 testing tolerance.

### Luminous Intensity Classification

BIN CODE	Iv(lm) at60mA	
	Min.	Max.
F18D	18	20
F20D	20	22
F22D	22	24
F24D	24	26
F26D	26	28
F28D	28	30

### Forward Voltage Classification

BIN CODE	Vf(v) at60mA	
	Min.	Max.
1	2.8	2.9
2	2.9	3.0
3	3.0	3.1
4	3.1	3.2
5	3.2	3.3
6	3.3	3.4
7	3.4	3.5
8	3.5	3.6



### Chromaticity Coordinates Specifications For Bin Grading

Color Coordiante at60mA									
CCT(K)	BIN CODE	1		2		3		4	
		X	Y	X	Y	X	Y	X	Y
5700K	57K-1	0.3376	0.3616	0.3292	0.3539	0.3293	0.3423	0.3371	0.3493
	57K-2	0.3371	0.3493	0.3293	0.3423	0.3294	0.3306	0.3366	0.3369
	57K-3	0.3292	0.3539	0.3207	0.3462	0.3215	0.3353	0.3293	0.3423
	57K-4	0.3293	0.3423	0.3215	0.3353	0.3222	0.3243	0.3294	0.3306

CIE Chromaticity Diagram

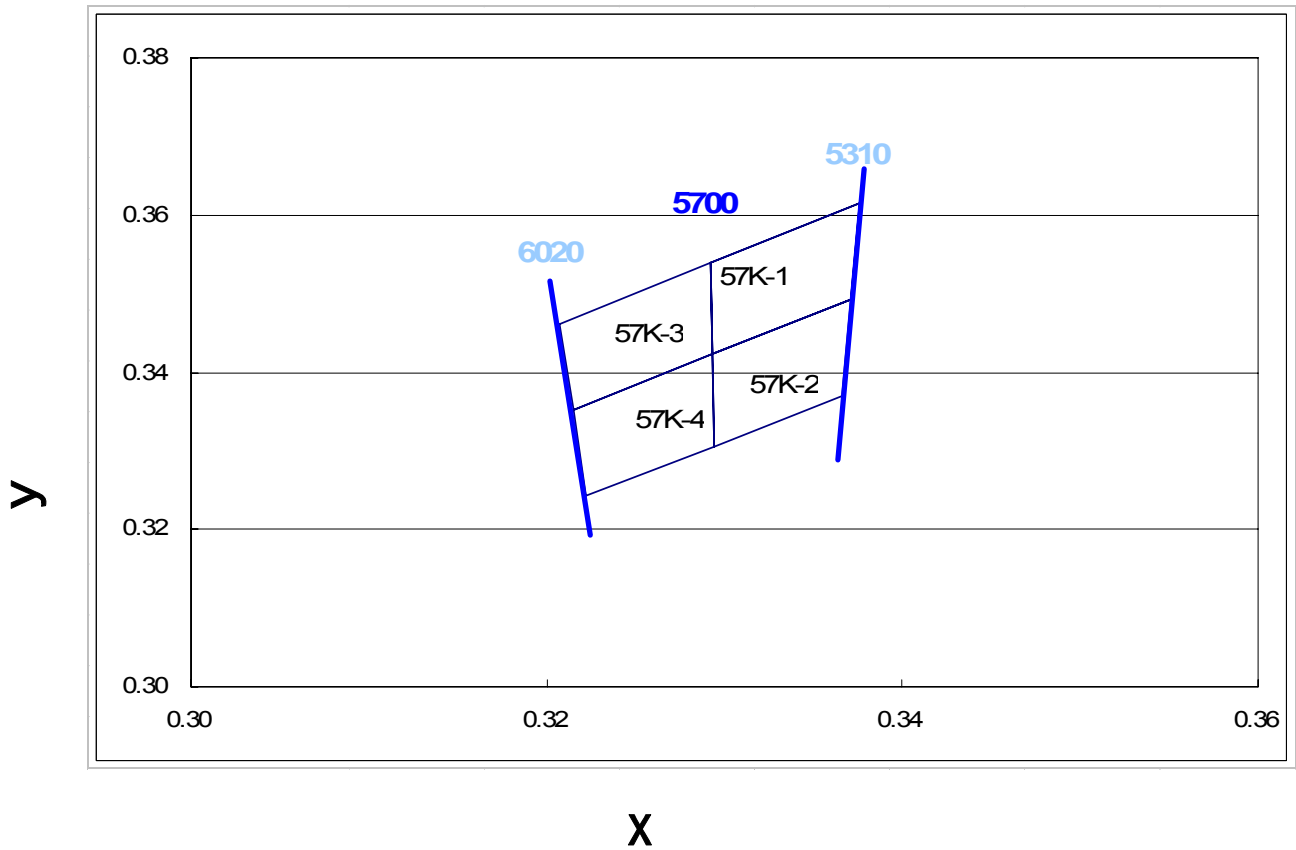

## Typical Electro-Optical Characteristics Curve

Fig.1 Forward current vs. Forward Voltage

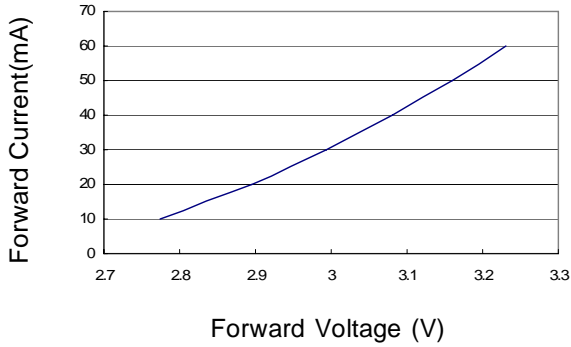

Fig.2 Forward Current vs. Temperature

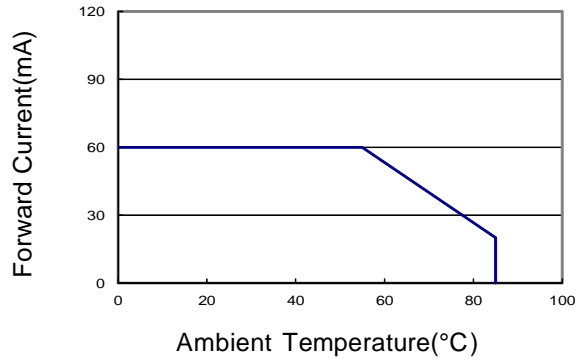

Fig.3 Forward current vs. Luminous Intensity

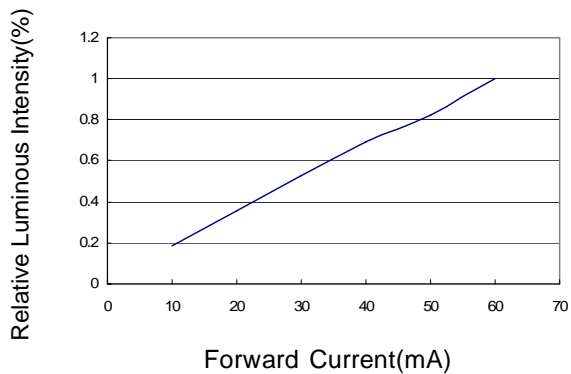

Fig.4 Forward Voltage vs. Temperature

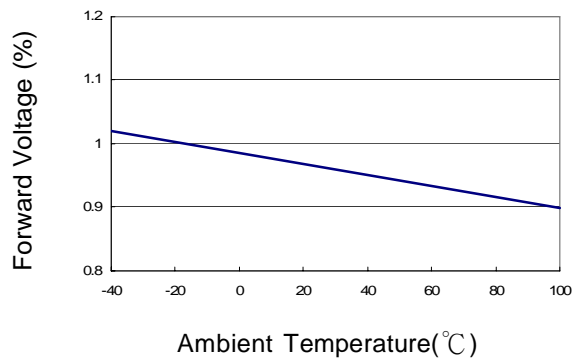

Fig.5 Luminous Spectrum (Ta=25°C)

### SPECTRAL RADIANCE

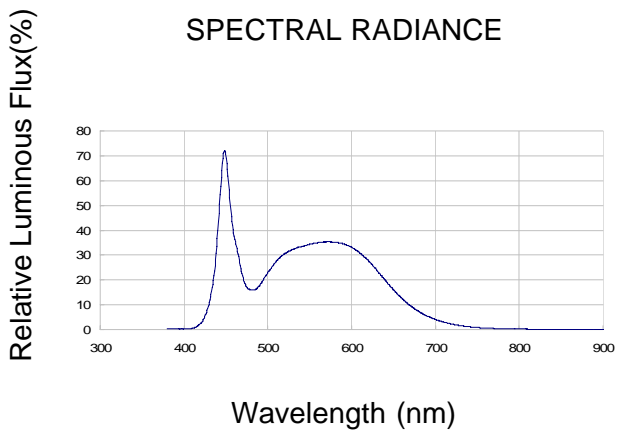
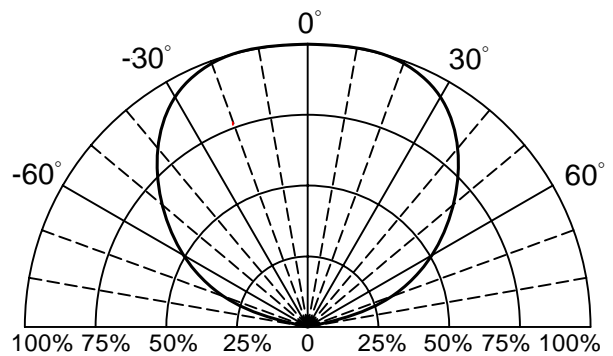
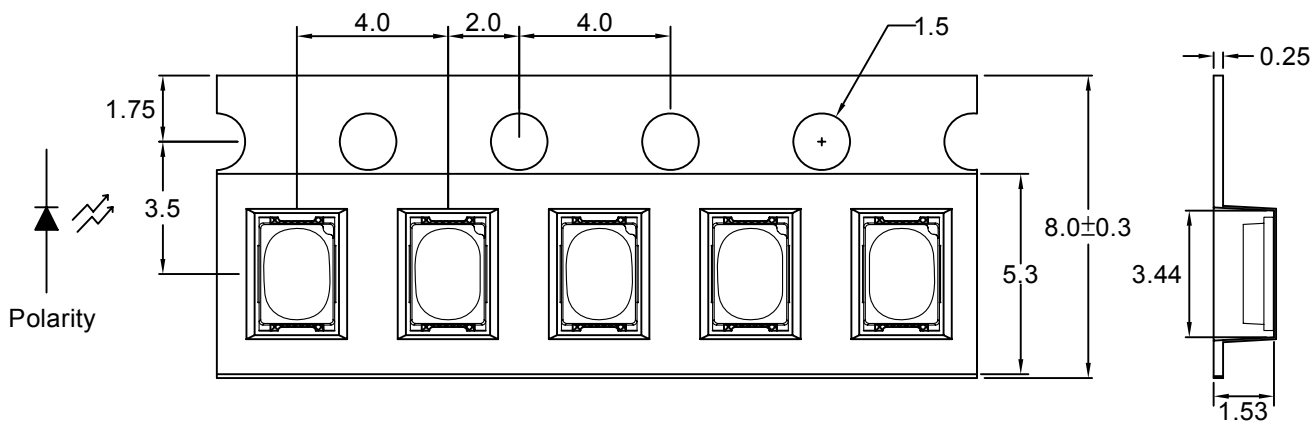

Fig.6 Directivity Radiation





### Carrier Type Dimensions



Note : The tolerances unless mentioned is  $\pm 0.1\text{mm}$ , Angle  $\pm 0.5$ . Unit=mm.

#### • Packing Specifications

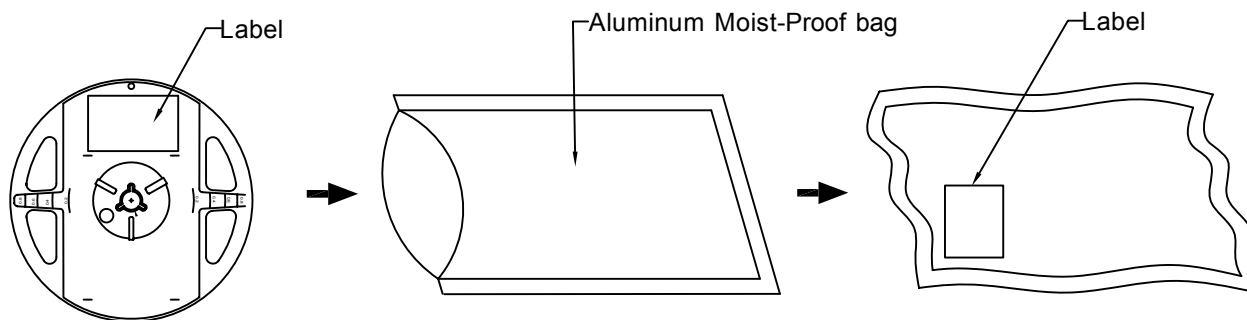

Part No.	Description	Quantity/Reel
LWK9S53-HC-T60-C-D702	8.0mm tape, 7" reel	2000 PCS

## Label Explanation

	LIGITEK ELECTRONICS CO., LTD.	
PART :	LWK9S53-HC-T60-C-D702	
LOT :	GS11410168	
QTY(PCS):	2000	
BIN/HUE :	F18/57K-2	VF:3.0-3.1

BIN : Luminous Flux

HUE : Chromaticity Coordinates  
(CIE\_x , CIE\_y)

VF : Forward Voltage

## Reel Dimensions

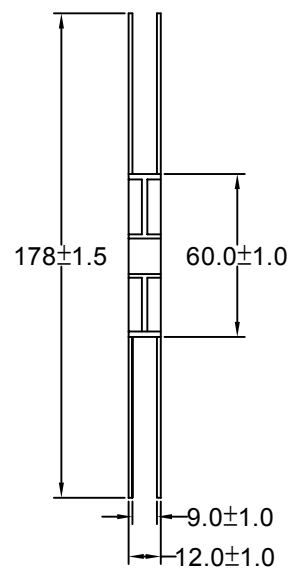
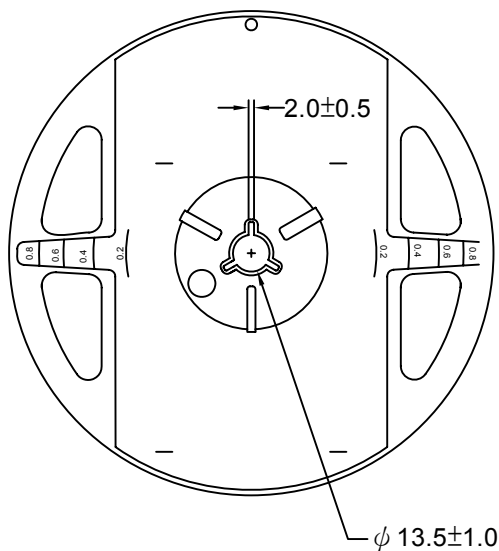

## Box Explanation

1. 5 BAG / INNER BOX

2. INNER BOX SIZE : L X W X H 23cm X 8.5cm x 26cm

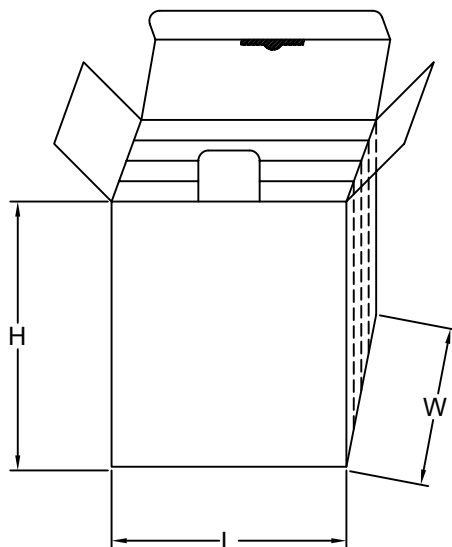

3. 10 INNER BOXES / CARTON

4. CARTON SIZE : L X W X H 58cm X 34cm x 35cm

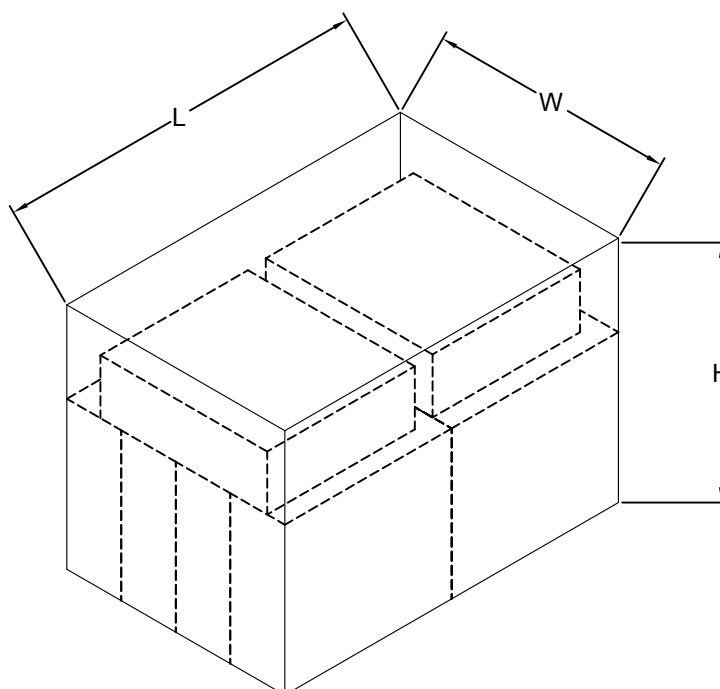

**Recommended Soldering Conditions****1. Hand Solder**

Basic spec is  $\leq 320^{\circ}\text{C}$  3 sec one time only.

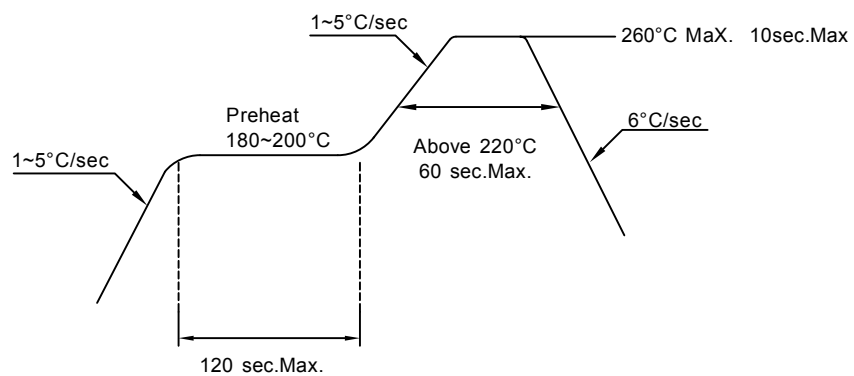
**2. PB-Free Reflow Solder****Note:**

- 1.Reflow soldering should not be done more than two times.
- 2.When soldering,do not put stress on the LEDs during heating.
- 3.After soldering,do not warp the circuit board.

**Precautions For Use:****Storage time:**

1. Calculated shelf life before opening is 12 months at  $< 30^{\circ}\text{C}$  and  $< 90\%$  relative humidity (RH)
2. After bag is opened, devices which will be subjected to reflow soldering or other high temperature processes must be
  - a) Assembled within 168 hours in an environment of  $\leq 30^{\circ}\text{C} / 60\%$  RH, or
  - b) Stored at ambient of 10% RH or less
3. Devices are required baking before assembly if:
  - a) Humidity Indicator Card reads  $>10\%$  (for level 2a -5a) or  $>60\%$  (for level 2) at ambient temperature  $23 \pm 5^{\circ}\text{C}$
  - b) 2.a) or 2.b) doesn't meet
4. If baking is required, devices should be baked for  $>72$  hours at  $60 \pm 5^{\circ}\text{C} / 5\%$  RH. Performing baking only once, and using the baked devices within 72 hours.

**Drive Method:**

LED is a current operated device, and therefore, requires some kind of current limiting incorporated into the driver circuit. This current limiting typically takes the form of a current limiting resistor placed in series with the LED.

Consider worst case voltage variations than could occur across the current limiting resistor. The forward current should not be allowed to change by more than 40% of its desired value.

Circuit model A

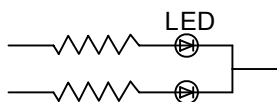

Circuit model B

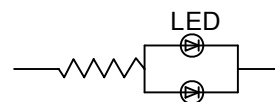

(A) Recommended circuit.

(B) The difference of brightness between LED could be found due to the VF-IF characteristics of LED.

**Cleaning:**

Use alcohol-based cleaning solvents such as isopropyl alcohol to clean the LED.

**ESD(Electrostatic Discharge):**

Static Electricity or power surge will damage the LED. Use of a conductive wrist band or anti-electrostatic glove is recommended when handling these LED. All devices, equipment and machinery must be properly grounded.

Reliability Test:

Classification	Test Item	Test Condition	Sample Size
Endurance Test	Operating Life Test	1.Ta=25°C 2.If=60mA 3.t=1000 hrs (-24hrs,+72hrs)	22
	High Temperature Storage Test	1.Ta=100°C±5°C 2.t=1000 hrs (-24hrs,+72hrs)	22
	Low Temperature Storage Test	1.Ta=-40°C±5°C 2.t=1000 hrs (-24hrs,+72hrs)	22
	High Temperature High Humidity Storage Test	1.Ta=85°C 2.RH=85% 3.t=1000hrs(-24hrs,+72hrs)	22
Environmental Test	Thermal Shock Test	1.Ta=100°C±5°C ~ -40°C±5°C 20min/ 10sec / 20min 2.total 100 cycles	22
	Temperature Cycling	1.100°C±5°C ~ -40°C±5°C 30mins / 5mins / 30mins 2.100 Cyeles	22
	IR Reflow	1.T=260°C Max. 10sec.Max. 2. 6 Min	22